

# Flood Risk Drainage Assessment

Proposed OCGT North

EP Energy Developments Limited

Project number: 60661667

August 2023

### Quality information

Prepared by	Checked by	Verified by	Approved by
Aparna Jamgade Apprentice	Peter O'Connor MRICS MCIWN		
Technical Teams Various	Peter O'Connor Associate Director	Simon Wells Associate Director	Simon Wells Associate Director

### Revision History

Revision	Revision date	Details	Authorized	Name	Position
0	August 2023	Drainage Layout	SW	Simon Wells	Associate Director

### Distribution List

# Hard Copies	PDF Required	Association / Company Name

**Prepared for:**

EP Energy Developments Limited

**Prepared by:**

AECOM Infrastructure & Environment UK Limited  
9th Floor, The Clarence West Building  
2 Clarence Street West  
Belfast BT2 7GP  
United Kingdom

T: +44 28 9060 7200  
aecom.com

© 2023 AECOM Infrastructure & Environment UK Limited. All Rights Reserved.

This document has been prepared by AECOM Infrastructure & Environment UK Limited ("AECOM") for sole use of our client (the "Client") in accordance with generally accepted consultancy principles, the budget for fees and the terms of reference agreed between AECOM and the Client. Any information provided by third parties and referred to herein has not been checked or verified by AECOM, unless otherwise expressly stated in the document. No third party may rely upon this document without the prior and express written agreement of AECOM.

## Table of Contents

1.	Introduction.....	6
2.	Background Information .....	7
2.1.	Site Description.....	7
2.1.1.	Site Location.....	7
2.1.2.	Site Description & Topography.....	8
2.1.3.	Existing Drainage Network.....	9
2.2.	Geology .....	9
2.3.	Watercourses.....	10
2.3.1.	Flood Defences.....	10
2.3.2.	Artificial Waterbodies .....	10
3.	Stage 1 - Flood Risk Identification .....	12
3.1.	Hydrometric Data.....	12
3.2.	OPW Hazard Maps and Historic Flood .....	13
3.3.	Groundwater Wells and Springs .....	14
3.4.	OPW Land Benefitting Maps.....	15
3.5.	Flooding from Overland Flow.....	15
3.6.	Conclusion – Stage 1.....	16
4.	Stage 2 – Initial Flood Risk Assessment.....	17
4.1.	Determination of Vulnerability .....	17
4.2.	Determination of Flood Zone .....	17
4.2.1.	Fluvial Flooding.....	18
4.2.2.	Pluvial Flooding .....	18
4.2.3.	Coastal Flooding.....	18
4.3.	Justification Test.....	19
4.4.	Environmental Impact Assessment.....	19
4.5.	Conclusion: Stage 2.....	20
5.	Stage 3 - Detailed Flood Risk Assessment.....	21
5.1.	Proposed Development .....	21
5.2.	Foul Drainage .....	21
5.2.1.	Existing Foul Drainage.....	21
5.2.2.	Proposed Foul Drainage.....	21
5.2.3.	Existing Surface Water Drainage .....	22
5.2.4.	Proposed Surface Water Drainage .....	22
5.2.4.1.	Preliminary Calculation:.....	22
	Greenfield run-off rate estimation.....	23
	Surface water storage volume estimation .....	23
5.3.	Mitigation Measures.....	24
6.	Conclusion.....	25
	Appendix A.....	26
A.1	Site Location.....	26
	Appendix B.....	27
B.1	Existing Site Topographical Survey.....	27
	Appendix C.....	28
C.1	Proposed Layout Plan.....	28
	Appendix D.....	29
	Record Drawings of Existing Tynagh Power Station .....	29
D.1	Existing services Layout .....	29
D.2	Storm Water Drainage layout.....	29

D.3	Sanitary Services and Drainage Layout.....	29
D.4	Sewage Treatment Plant Layout.....	29
<b>Appendix E</b> .....		<b>30</b>
E.1	Proposed Drainage Layout.....	30
<b>Appendix F</b> .....		<b>31</b>
F.1	Greenfield Run-off Rate Calculation Report.....	31
F.2	Surface Water Storage Calculation Report.....	31
<b>Appendix G</b> .....		<b>32</b>
G.1	Percolation Test.....	32

## Figures

Figure 1: Proposed Development Site Location (Source: <a href="http://www.googlemap.com">www.googlemap.com</a> ).....	7
Figure 2: Local Topography.....	8
Figure 3: Bedrock Geology 100k (Group) - GSISR Index.....	9
Figure 4: Location of nearby watercourses ( <a href="http://www.floodinfo.ie">www.floodinfo.ie</a> ).....	10
Figure 5: Location of Artificial waterbodies ( <a href="http://www.googlemap.com">www.googlemap.com</a> ).....	11
Figure 6: Photograph of Existing Lagoon.....	11
Figure 7: Location of Hydrometric Gauging Station.....	12
Figure 8: OPW Flood Hazard Map.....	13
Figure 9: Historic Surface water Flooding ( <a href="http://www.floodinfo.ie">www.floodinfo.ie</a> ).....	14
Figure 10: Groundwater Wells and Springs.....	14
Figure 11: Land Benefitted from OPW Schemes.....	15
Figure 12: Flood Hazard Extents (Source: OPW – <a href="http://www.floodinfo.ie">www.floodinfo.ie</a> ).....	18
Figure 13: Coastal Flooding Extent (Source: OPW – <a href="http://www.floodinfo.ie">www.floodinfo.ie</a> ).....	19
Figure 14: Clipping from Greenfield run off rate report – (Source: HR Wallingford Online tool).....	23
Figure 15: Surface water storage (Source: HR Wallingford Online tool).....	23

## Tables

Table 1 Hydrometric Gauging Station.....	13
Table 2: Historic Flood Events.....	13
Table 3: Classification of Vulnerability (Source: The Planning System and Flood Risk Management - Guidelines for Planning Authorities).....	17
Table 4: Flood Zone Description (Source: The Planning System and Flood Risk Management - Guidelines for Planning Authorities).....	18
Table 5: Justification Test Matrix (Source: The Planning System and Flood Risk Management - Guidelines for Planning Authorities).....	19

# 1. Introduction

AECOM were commissioned by EP Energy Development Limited ('the Applicant') to produce a Flood Risk & Drainage Assessment (FRDA) in relation to a new Open Cycle Gas Turbine (OCGT) plant and all associated ancillary development and connection infrastructure, site works and services ('the Proposed Development') on land within and to the immediate north of Tynagh CCGT Power Station in Loughrea, Co. Galway.

In accordance with 'The Planning System and Flood Risk Management - Guidelines for Planning Authorities (Nov 09)' there is a requirement to undertake a Flood Risk Assessment (FRA) Report, which will accompany the planning application.

AECOM is required to undertake a Site-Specific Flood Risk Assessment (FRA) for the Proposed Development.

The FRA study has been undertaken in consideration of the following guidance document:

- The Department of Environment, Heritage, and Local Government (DEHLG 2009) has introduced the guidelines for planning Authorities - The Planning System and Flood Risk Management. Further, the Office of Public Works (OPW) and DEHLG work together in assisting technical aspects of the implication of the guidelines. The guidelines state the requirement of flood risk assessment at the earliest stages of development under Planning Code.

The report will demonstrate in the following assessments stages:

**Stage 1 – Flood risk identification** – to identify whether there may be any flooding or surface water management issues related to either the area of regional planning guidelines, development plans and LAP's or a proposed development site.

**Stage 2 – Initial flood risk assessment** – to confirm sources of flooding that affect a plan area or proposed development site.

**Stage 3 – Detailed flood risk assessment** – to assess flood risk issues in sufficient detail and to provide a quantitative appraisal of potential flood risk to a proposed or existing development and of the selectiveness of any proposed mitigation measures.

This document is a combined Flood Risk & Drainage Assessment (FRDA), written for Chapter 12 (Water Environment) of the accompanying Environmental Impact Assessment Report (EIAR) for Tynagh North OCGT. Other environmental impact assessment is beyond the scope of the FRDA (e.g. water quality, hydrogeology, water resources, hydromorphology, etc.) are described in the EIAR.

## 2. Background Information

### 2.1. Site Description

#### 2.1.1. Site Location

The site is located approx 1.5 km north of the village of Tynagh, Co. Galway. The proposed development overall project is situated within the site grounds of Tynagh Power Plant, near Loughrea, Co. Galway. The entire site is located within the administrative area of Galway County Council (GCC). The site is controlled by EP Energy Development Limited.

It covers an area of approximately 8.30 ha consisting of industrial (energy) and brownfield site and is bordered to the east by the former Tynagh Mine and to the south by the Tynagh CCGT Power Station.

Figure 1 from the site location plan indicates the red line site boundary. The site boundary encompassing the Proposed Development is included in Appendix A. (Easting: 174427, Northing: 213116, Irish grid reference).



Figure 1: Proposed Development Site Location (Source: [www.googlemap.com](http://www.googlemap.com))

## 2.1.2. Site Description & Topography

The proposed development is to be located within the existing power station lands on the northern side of the Tynagh Power Station site (Grid Reference E: 174427 N: 213116). The entire site is under the control of EP Energy Development Ltd.

The site on which the proposed development will be located is a combined brownfield and industrial land which will be the location for the new Tynagh North Open Cycle Gas Turbine (OCGT) plant and all associated ancillary development and connection infrastructure, site works and services.

The topographic survey of the site was undertaken by Murphy Geospatial in July 2021, and this is used to inform a description of levels at the Proposed Development.

Figure 2 (below) from the topographic survey information indicates that the site slopes from western boundary to centre of the site with levels between 73.4 m to 68.3m Above Ordnance Datum (m AOD). Part of the eastern boundary has a woodland area (not included in the survey). The levels from the end of this area fall in a north-westerly direction, with levels between 72.62 m and 62.1 m AOD. The southern boundary to the Tynagh power station lies between 69.9 m and 67.2 m AOD. Similarly, the southwest boundary decreases from 67.8 m to 64.87 m AOD. Existing gravel roads provide access levels between 72.3 m and 64.1 m AOD.

The undeveloped land on the site will be used for the construction of infrastructure. The existing topography of this land falls from the central west to eastern boundary with levels between 67.2 m and 62.8 m AOD and 71.1 m to 70.5 m AOD. Refer to Appendix B of this document for the topographical survey of the existing site.

The proposed internal access road which will be extended from the existing road located on the eastern side of the power station is at the level of 67.1 m AOD. A newly constructed east-west road will provide access to the proposed fuel oil storage facility. It will run along the periphery of the Switchyard, Air Intake, OCGT, Stack and Fin Fan Coolers. Refer to the Proposed Development site layout included in Appendix C of this report.



Figure 2: Local Topography



### 2.1.3. Existing Drainage Network

Refer to Appendix D for record drawings of the current surface water and foul water drainage network at Tynagh Power Station. The drawing indicates that the existing power station site is positively drained to the eastern boundary of the site where the on-site wastewater treatment plant is located. More details regarding the existing drainage network are provided in Section 5 of this report.

The topographic survey indicates that the gravel area located along the western boundary and the central area of the proposed site has existing drainage infrastructure.

## 2.2. Geology

A review of the Geological Survey of Ireland Spatial Resources (GSISR) provides datasets for bedrock, quaternary, groundwater, marine, geological heritage etc. The online mapping (Figure 3 below) indicates the site is underlain by dark limestone and shale. The formation comprises dark-grey to black, fine-grained, occasionally cherty, micritic limestones that weather paler, usually to pale grey. There are rare dark coarser-grained calcarenitic limestones, sometimes graded, and interbedded dark-grey calcar

Natural infiltration rates are therefore likely to be high; however, any infiltration rates specified in the final drainage design (if applicable) should be determined by in-situ testing to BRE Digest 365 specifications.

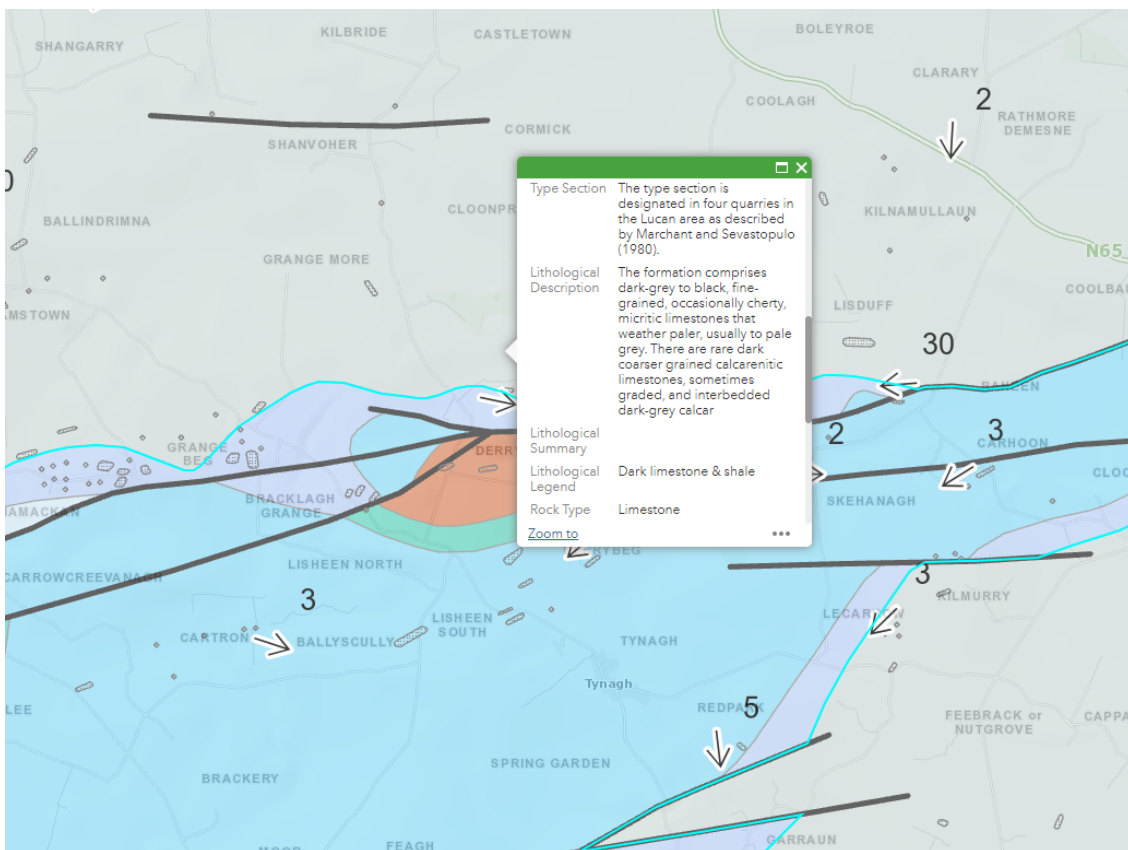

Figure 3: Bedrock Geology 100k (Group) - GSISR Index

## 2.3. Watercourses

OPWs national flood information portal provides location specific access to flood risk and flood management information. The website floodInfo.ie provides interactive map to view up-to-date flood hazard, flood risk, drainage map etc information.

Drainage map is subdivided into Arterial Drainage Scheme (ADS), Drainage Districts (DD) and Land Commission (LC). As per ADS, the channels layer identifies the watercourses. which. This arterial channel links is C1/20/5/3, C1/20/5/2, C1/20/5, C1/20, C1 (Kilcrow River). The Kilcrow river is located approximately 2.3 km to the northwest from the proposed development and flows in a southward's direction forming a confluence with Duniry River. The Duniry River also discharges in the Lough Derg - 12km south of the proposed site. Further, River Shannon flows approximately 17km east of the site. The Shannon River flows from the north from Athlone southwards and south westerly towards Lough Derg.

Figure 4 below is extracted from the floodinfo.ie mapping website, indicating the location of arterial channels within the site constraints. It also indicates that there is a stream to the south of the existing enclosed lagoon (C1/20/3/1). It is estimated that the stream is located approximately 500m south of the Proposed Development. It flows in an easterly direction where it forms a confluence with the Kilcrow River.

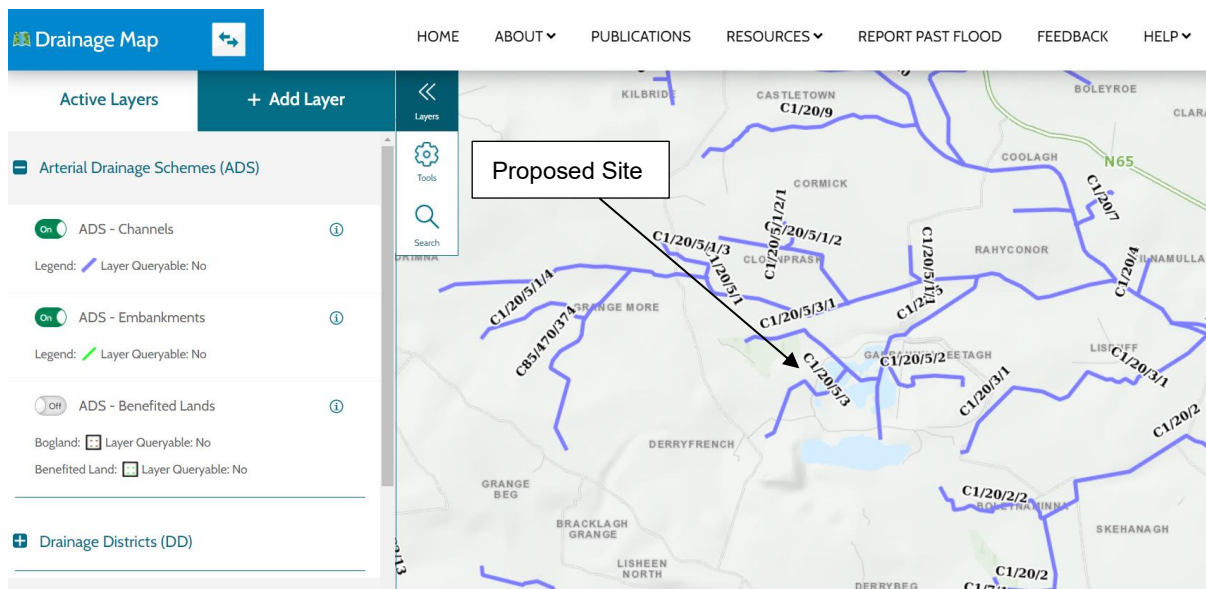

Figure 4: Location of nearby watercourses (Source: www.floodinfo.ie)

### 2.3.1. Flood Defences

There are no flood defences located on the proposed site or within the vicinity of the site.

### 2.3.2. Artificial Waterbodies

At its closest point to Tynagh Mine, which is an enclosed in open water (lagoon), the site is located approximately 280m to the eastern boundary of the site. Further Tynagh Mine tailings ponds form open water bodies which are approximately 500m to the south boundary of the Site at their closest point. Figure 5 shows the location of mine waterbodies within site constraints and Figure 6 below shows a photograph of the existing Mine lagoon.



**Figure 5: Location of Artificial waterbodies (Source: [www.googlemap.com](http://www.googlemap.com))**



**Figure 6: Photograph of Existing Lagoon**

### 3. Stage 1 - Flood Risk Identification

The purpose of Stage 1 is to establish whether a flood-risk issue exists or may exist in the future. If there is a potential flood risk issue then, in accordance with 'The Planning System and Flood Risk Management – Guidelines for Planning Authorities (DOEHLG 2009)', the flood risk assessment procedure should move to 'Stage 2 – Initial Flood Risk Assessment'. If no potential flood risk is identified during Stage 1 then the overall flood risk assessment can be concluded.

The following information and data have been collated as part of the screening assessment for the Proposed Development.

As part of the Government's Strategy Office of Public Works (OPW), Ireland has assessed and mapped the flood extent, hazard, and risk for a range of flood events from frequent, minor flood events up to very rare, extreme events. The OPW hosts an online interactive map viewer illustrating Flood Hazard Maps (<https://www.floodinfo.ie/map/floodmaps/>) describe the characteristics of the predicted flood for each scenario and include information such as flood extent, flood depth and level, and the flow of floodwater.

An interactive mapping tool illustrates flood maps (fluvial), flood plans, drainage maps (pluvial), and coastal maps (coastal) in both detailed and estimated form. Detailed modelling has been completed in many of the highly populated urban areas in Ireland with all other locations strategically estimated in regard to flood extent and inundation.

#### 3.1. Hydrometric Data

Existing sources of hydrometric data from the Environmental Protection Agency (EPA) (<https://gis.epa.ie/EPAMaps/Water>) were investigated, as summarised in Table 1. This investigation has determined that there is only one gauging station (Irish Grid Reference: X= 177222; Y= 213439) approximately 3km to the east of the Site as shown in Figure 7.

The gauging station is located on the Kilcrow River which is classified as a stream in the hydrometric data summary in Table 1.

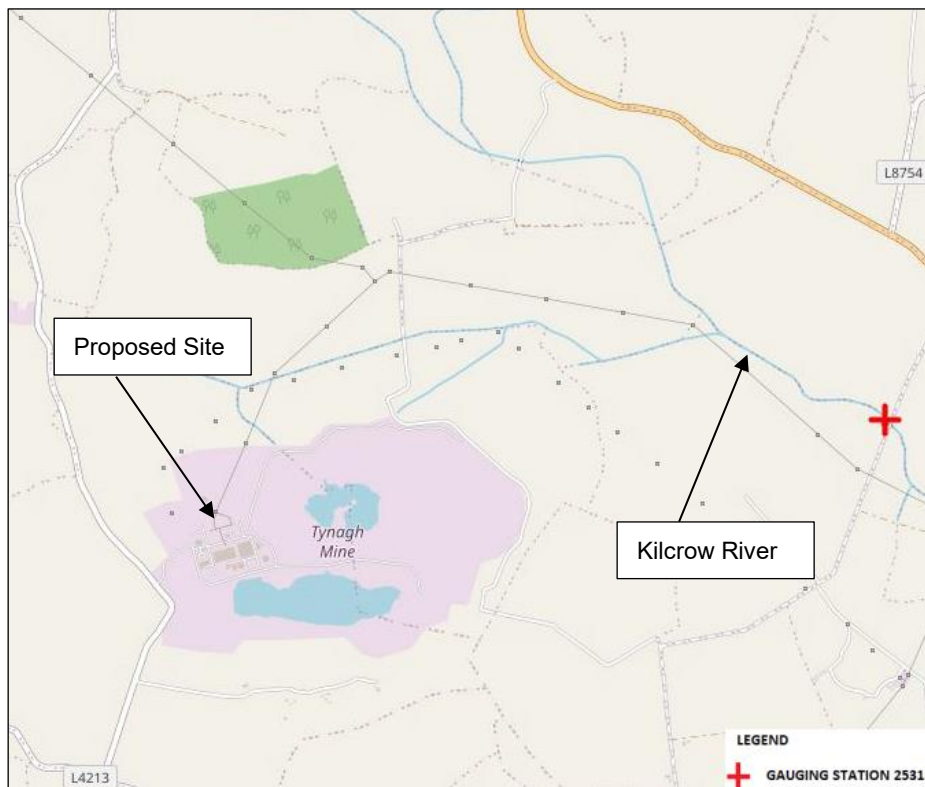

Figure 7: Location of Hydrometric Gauging Station

Table 1 summarises the hydrometric data associated with Gauging Station 25315 and indicates the status of the gauging station as inactive.

Station No.	Name	Status	Waterbody	Owner	Available Data
25315	Coolbaun West	Inactive	Stream	Galway County Council	Spot flow measurements only - No continuous water level or flow records available.

Table 1 Hydrometric Gauging Station

### 3.2. OPW Hazard Maps and Historic Flood

The Office of Public Works (OPW) Flood Hazard Maps Website ([www.floodmaps.ie](http://www.floodmaps.ie)) is cross checked in relation to available historical or anecdotal information on any flooding incidences or occurrence in the vicinity of the Site.

No flood events have been recorded within the Site boundary. Figure 8 and Table 2 below shows mapping from the aforementioned website, which indicates that there is one recurring flood event (ID: 1923) approximately 1km southwest of the Site. The remaining flooding incidents are greater than 2.5km from the Site, and the OPW Flood Hazard Map only describes flooding incidents within 2.5km from the Site.

ID No.	Event Type	Title	Description
ID-1923	Recurring	Bracklagh Grange, Tynagh	-Low lying land floods every year after heavy rain.

Table 2: Historic Flood Events

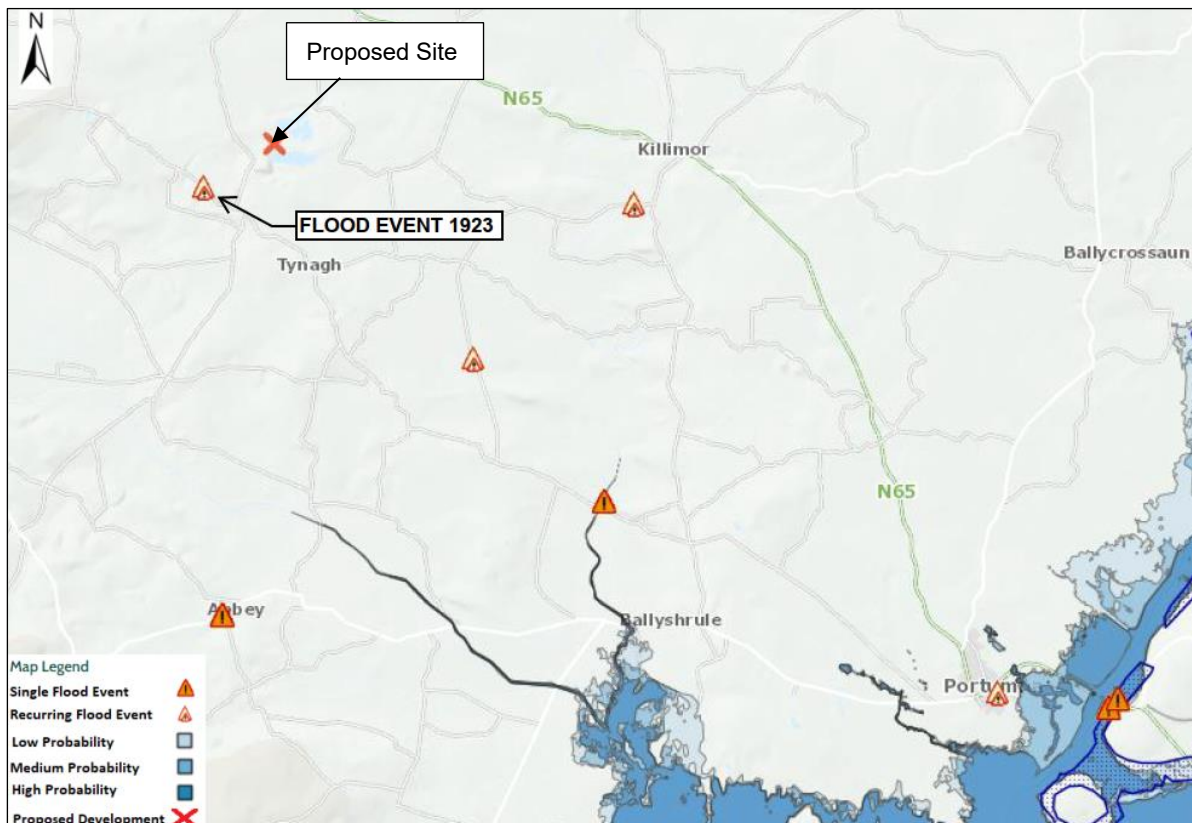

Figure 8: OPW Flood Hazard Map

While no flood history is recorded within the Site, this may be due to the historical usage of the existing mine site and the presence of surface waterbodies and the network of nearby streams discharging to the Kilcrow River.

Figure 9 below displays a screen shot of the flood map generated at the site location indicates the extents of the past flood events and extents. A very small portion of the existing mine lagoon is defined as a historic flood area (Winter 2015/2016 Surface Water Flooding) located approximately 500m south to the Site.

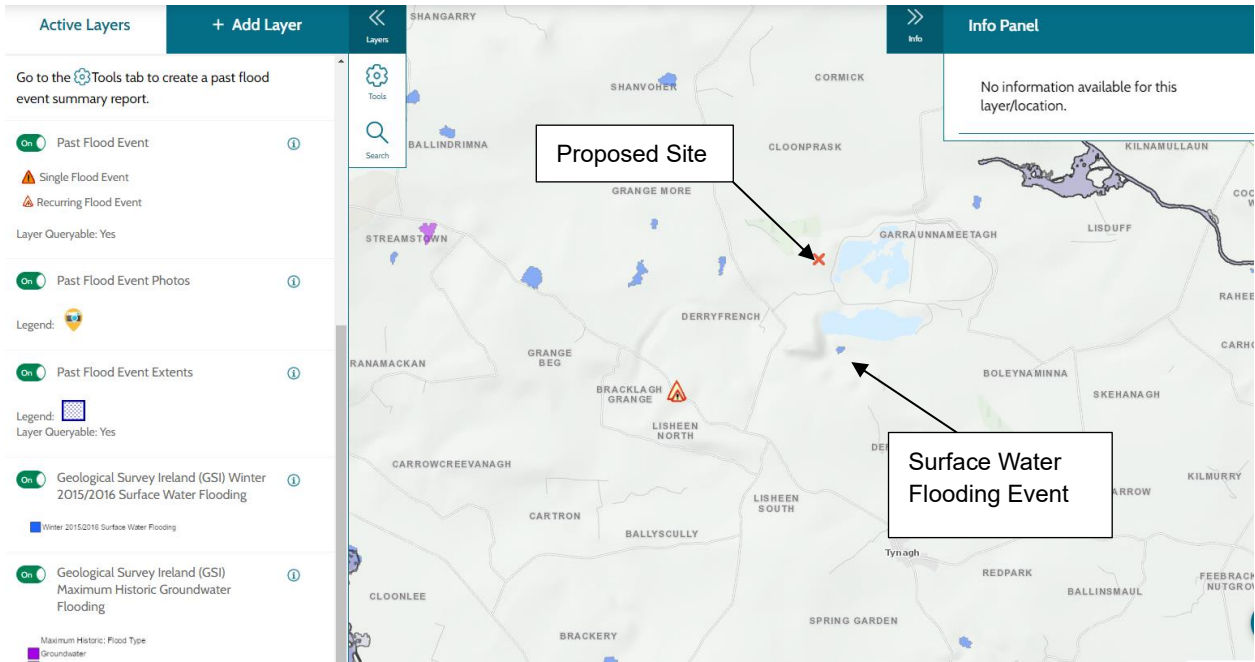

Figure 9: Historic Surface water Flooding (Source: www.floodinfo.ie)

### 3.3. Groundwater Wells and Springs

An investigation into the rise and abstraction of water from underground wells and springs (Figure 9) around the former mine site was taken from the Department of Communications, Climate Change and Environment (<http://dcenr.maps.arcgis.com>). This was to identify if there are any areas of rising groundwater that could contribute to flooding.

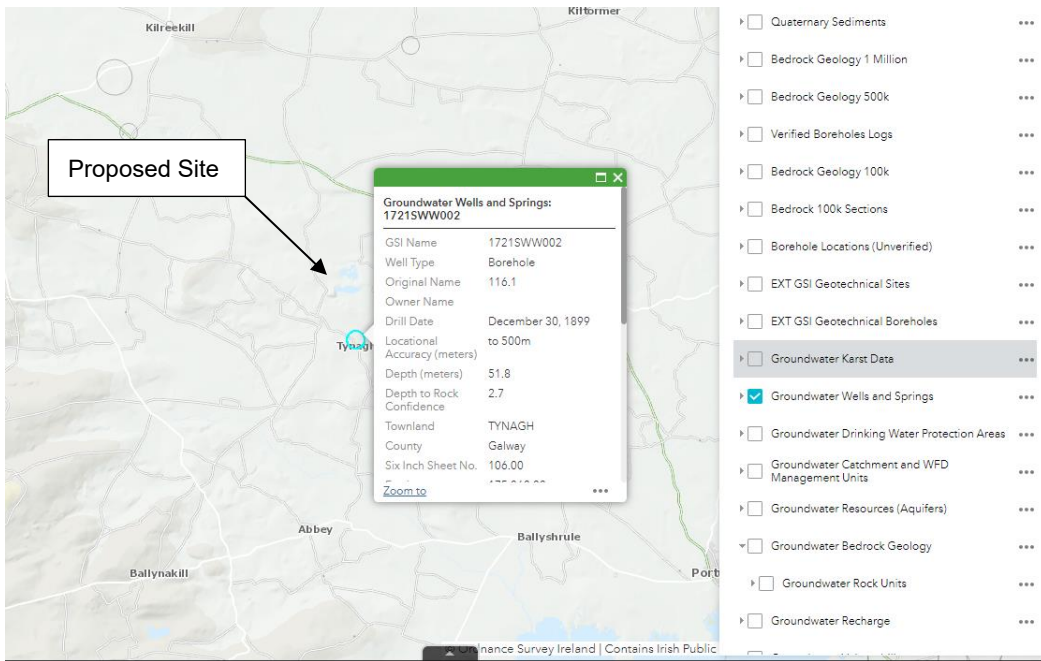

Figure 10: Groundwater Wells and Springs (Source: dcenr.maps.arcgis.com)

The mapping of local groundwater wells, springs in Figure 10 indicates the nearest borehole is located approximately 1.4km to the south of the Site. Records indicate the borehole (GSI Name - 1721SWW002) is used for agriculture and domestic uses.

### 3.4. OPW Land Benefitting Maps

Arterial Drainage Schemes (ADSs) were carried out under the Arterial Drainage Act, 1945 to improve land for agriculture and to mitigate flooding. Rivers, lakes, weirs and bridges were modified to enhance conveyance, embankments were built to control the movement of flood water and various other work was carried out under Part II of the Arterial Drainage Act, 1945.

The purpose of the schemes was to improve land for agriculture, to ensure that the three-year flood was retained in bank, this was achieved by lowering water levels during the growing season to reduce waterlogging on the land beside watercourses known as callows. Flood protection in the benefiting lands was increased as a result of the Arterial Drainage Schemes. It is noted that these schemes were only designed to retain the three-year flood which is a standard well below what would be required for development of any land.

Figure 11 indicates the stream network to the north and the northwest of the Site benefits from OPW Arterial Drainage Schemes, with the closest scheme being the C1/20/5/3 Killimor/ Cappagh scheme.



Figure 11: Land Benefitted from OPW Schemes

It is noted that some of the channels have since been infilled and abandoned or relocated as the former, now closed, Tynagh Mine site developed over time.

### 3.5. Flooding from Overland Flow

EP Energy Developments Limited have provided AECOM with information relating to minor historic flooding incidents on the western boundary of the Tynagh Power station CCGT Site (but not on the Proposed Site) dating from November 2009 and December 2015. From the information provided and following discussions with the client and site inspection, AECOM have concluded that these isolated incidents are caused by prolonged rainfall events leading to saturated ground conditions and higher than normal runoff from the surrounding areas.

It is considered that the topography of the area may result in overland flow being generated within the catchment upstream of the existing CCGT Power Station Site which then uses the LP4310 Gurtymaden (note- some public documents refer to this road as Gortymadden) to Tynagh Road as a flow path. The access road to the Site allows flow to escape from the LP4310 Gurtymaden to Tynagh Road. An existing hard area external to the

CCGT Power Station site entrance, which sits in a slight depression, has limited surface water drainage measures, which when combined with the overland flow, leads to a small ponding of water, to a depth of circa 300mm.

During the past flooding events the onsite teams have deployed precautionary sandbags and pumps to prevent the overland flows potentially reaching the existing CCGT Power Station site. A land drain has also been constructed along the western boundary of the Site that takes flows in a northerly direction which is considered to have alleviated the situation. The topography of the area is such that flows would have originally travelled in a north-easterly direction and so displacement of flows was not occurring without the development of this land drain.

Historically, additional pumping has also been deployed from the existing CCGT Power Station water treatment facility to the adjacent lagoon due the volume of surface water being experienced overwhelming the storage available. Permission has been obtained from EPA prior to this pumping taking place and it should be noted that the Power Station has not been flooded or been encroached by ponded flood water and has never had to shut down due to flooding.

The existing CCGT Power Station operational team has also developed a dedicated section of their "Off-Site Events with On-Site Impacts" emergency procedures relating to flooding which includes the following actions:

- Ensure all drains are clear of debris, including those off-site;
- Evacuation of areas of site which are at risk of flooding;
- Liaise with site neighbours for a co-ordinated response;
- Setup of flood water protection barrier;
- Setup of visible barriers to indicate the location of trenches and flood protection barriers;
- If necessary, contact EPA for permission to pump directly to discharge lake; and
- Monitor discharge pumps and regularly sample for water quality.

Given the above events that have occurred and the development of mitigation measures, AECOM are of the opinion that the risk of flooding from overland flow can be managed to a level that reduces the risk to low. Additional drainage design measures can also be introduced in this area such as localised regrading of levels by circa 300-500mm to cut-off the flow path into the Proposed Development and negating the need for emergency sand bagging.

## 3.6. Conclusion – Stage 1

The purpose of scoping stage 1 is to identify whether there may be any flooding or surface water management issues. It indicates that fluvial flooding of the Site from the Kilcrow River is unlikely. The topographical assessment indicates that existing topographic levels would allow excessive flow from the network of streams away from the Site.

Historic flood hazard map indicates one event, located greater than 2.5km away from the site. In the vicinity of the Tynagh Power station site, there are groundwater sources that indicate surface floods during prolonged periods of rain.

The groundwater flooding mapping provided, it appears that this area is referring to the lagoon which is located outside and to the south of the OCGT Site boundary. Furthermore, the topography of the Site and the immediate surrounds shows that any flooding from this location would flow away from the Site.

Existing surface water drainage records (Tynagh Power Station) attached as Appendix D indicate surface water runoff intercepted at the site is treated onsite and is then discharged to the existing lagoon to the south of the existing site. Embankments around the lagoon are raised to prevent treated surface water runoff from overflowing onto the site. Specific emergency procedures are in place for flooding should a repeat event occur.

There are no springs and groundwater discharges recorded in the immediate vicinity of the Site. The Department of Communications, Climate Change and Environment (<http://dcenr.maps.arcgis.com>) identifies the area south of the existing site and areas to the north of the existing site to be possibly at risk of flooding from groundwater



## 4. Stage 2 – Initial Flood Risk Assessment

In consideration of the flood risk identification, this assessment is required to proceed to ‘Stage 2 – Flood Risk Assessment’. The screening assessment requires the groundwater levels to be discussed in detail. In order to undertake the initial flood assessment, following determinations are required:

- flood zone in which the Site is located,
- vulnerability of the proposed works,
- type of development and flood zone designation and
- environmental impact assessment.

### 4.1. Determination of Vulnerability

The vulnerability of the proposed works is classified into three classes as given in Table 3 below.

Vulnerability class	Land uses and types of development*
Highly vulnerable development (including essential infrastructure)	Garda, ambulance and fire stations and command centres required to be operational during flooding; Hospitals; Emergency access and egress points; Schools; Dwelling houses, student halls of residence and hostels; Residential institutions such as residential care homes, children’s homes and social services homes; Caravans and mobile home parks; Dwelling houses designed, constructed or adapted for the elderly or, other people with impaired mobility; and Essential infrastructure, such as primary transport and utilities distribution, including electricity generating power stations and sub-stations, water and sewage treatment, and potential significant sources of pollution (SEVESO sites, IPPC sites, etc.) in the event of flooding.
Less vulnerable development	Buildings used for: retail, leisure, warehousing, commercial, industrial and non-residential institutions; Land and buildings used for holiday or short-let caravans and camping (subject to specific warning and evacuation plans); Land and buildings used for agriculture and forestry; Waste treatment (except landfill and hazardous waste); Mineral working and processing; and Local transport infrastructure.
Water-compatible development	Flood control infrastructure; Docks, marinas and wharves; Navigation facilities; Ship building, repairing and dismantling, dockside fish processing and refrigeration and compatible activities requiring a waterside location; Water-based recreation and tourism (excluding sleeping accommodation); Lifeguard and coastguard stations; Amenity open space, outdoor sports and recreation and essential facilities such as changing rooms; and Essential ancillary sleeping or residential accommodation for staff required by uses in this category (subject to a specific warning and evacuation plan).

\* Uses not listed here should be considered on their own merits

**Table 3: Classification of Vulnerability (Source: The Planning System and Flood Risk Management - Guidelines for Planning Authorities)**

The guidelines would indicate that the Proposed Development, as an OCGT electricity generating power station, should be considered to be **highly vulnerable development**.

### 4.2. Determination of Flood Zone

In accordance with ‘The Planning System and Flood Risk Management – Guidelines for Planning Authorities (DOEHLG 2009)’, there are three flood zones designated in the consideration of flood risk to a particular site. The three flood zones are described in 4.

Flood Zone	Description
Flood Zone A	Where the probability of flooding from watercourses is the highest (greater than 1% or 1 in 100 year for watercourse flooding or 0.5% or 1 in 200 for coastal flooding).
Flood Zone B	Where the probability of flooding from watercourses is moderate (between 0.1% or 1 in 1000 year and 1% or 1 in 100 year for watercourse flooding and between 0.1% or 1 in 1000 year and 0.5% or 1 in 200 for coastal flooding).
Flood Zone C	Where the probability of flooding from watercourses and the sea is low or negligible (less than 0.1% or 1 in 1000 year for both watercourse and coastal flooding). Flood Zone C covers all areas which are not in Zones A or B.

**Table 4: Flood Zone Description (Source: The Planning System and Flood Risk Management - Guidelines for Planning Authorities)**

The planning implications for each of the flood zones are described in detail in The Planning System and Flood Risk Management – Guidelines available on <https://www.opr.ie/wp-content/uploads/2019/08/2009-Planning-System-Flood-Risk-Mgmt-1.pdf>

**4.2.1. Fluvial Flooding**

Figure 12 (clipping from website) below displays a screen shot of the flood map generated at the site location and indicates the extents of the present day predicted fluvial flood plain for a 10 year (high probability), 100 year (medium probability) and 1000 year (low probability) year return period.

The modelled flood mapping indicates that the Project Site is not in a ‘Flood Risk Zone’ (i.e., Flood Zone C). As described in the guidelines, development in Zone C is appropriate from a flood risk perspective (subject to assessment of flood hazard from sources other than rivers and the coast) but would need to meet the normal range of other proper planning and sustainable development considerations.

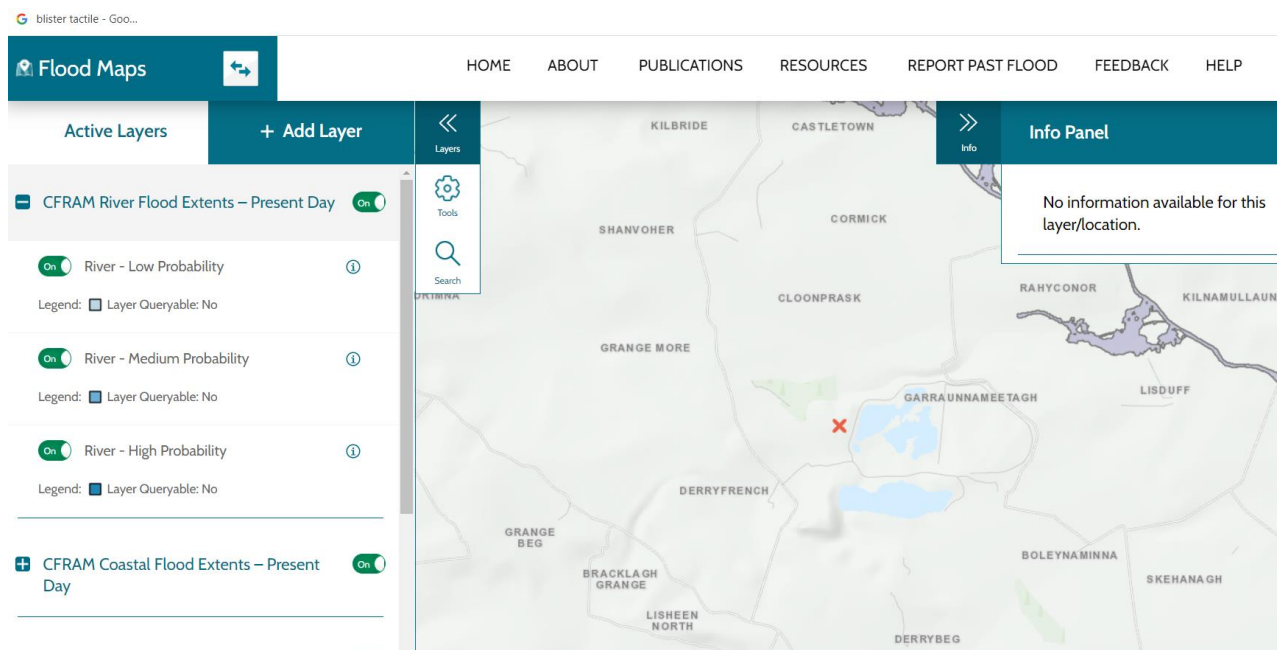

Undero

**Figure 12: Flood Hazard Extents (Source: OPW – www.floodinfo.ie)**

**4.2.2. Pluvial Flooding**

Sewer records for the existing Tynagh Power Station development are provided in Appendix D. The records and site inspection information indicate the existing site is served by an on-site private surface water sewer network. The surface water drainage network intercepts surface water runoff from the road network and hardstanding areas at the buildings and conveys the surface water runoff to an onsite treatment plant. Treated surface water is then discharged to the existing (former mine) lagoon to the south of the existing site under the existing site licence and discharge consent. Figure 5 indicates the embankments around the lagoon are raised to prevent treated surface water runoff from overflowing onto the site.

**4.2.3. Coastal Flooding**

Figure 13 (clipping from website) below displays a screen shot of the coastal map generated at the site location and indicates the extents of the present day predicted coastal flood plain for a 10 year (high probability), 100 year (medium probability) and 1000 year (low probability) year return period.

Although geographically, the Proposed Development Site is quite a distant from coastal area; the risk of coastal/sea flooding to the site has also been cross checked. From the Coastal Flood Extents maps confirm that

the site is not at risk from a 1 in 200 year (0.5% AEP) coastal/sea flood event. This mapping includes a consideration of sea level rise due to climate change.

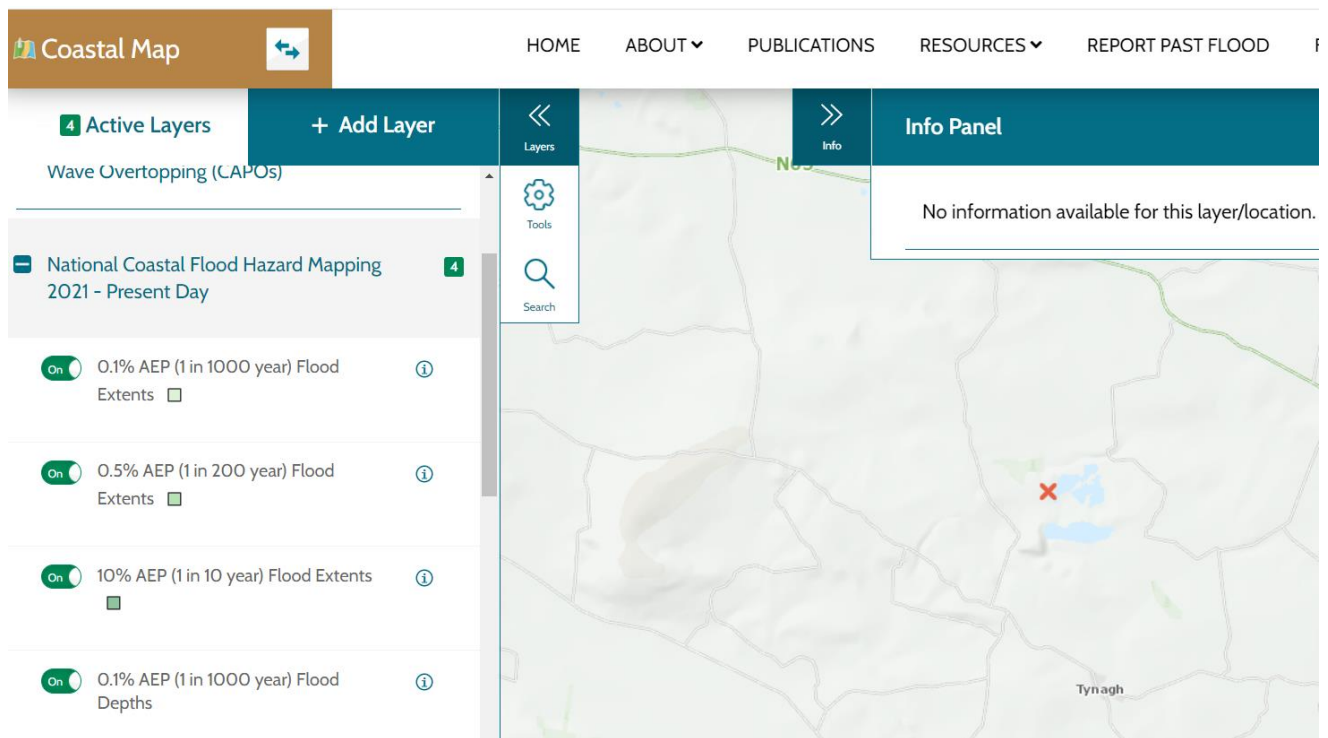

Figure 13: Coastal Flooding Extent (Source: OPW – www.floodinfo.ie)

### 4.3. Justification Test

The requirement for a justification test was reviewed for this study to determine whether the Proposed Development would be considered acceptable in terms of flood risk. The conclusion of ‘Stage 1 – Flood Risk Identification’ called for the vulnerability of the Proposed Development to be characterised in terms of defining its corresponding Flood Zone and the Sites appropriate use.

The requirement for a Justification Test is determined based on the type of development and flood zone designation as indicated in Table 5 below.

	Flood Zone A	Flood Zone B	Flood Zone C
Highly Vulnerable Development	Justification Test	Justification Test	Appropriate
Less Vulnerable Development	Justification Test	Appropriate	Appropriate
Water-Compatible Development	Appropriate	Appropriate	Appropriate

Table 5: Justification Test Matrix (Source: The Planning System and Flood Risk Management - Guidelines for Planning Authorities)

Given the determination of the Site is located in Flood Zone C and is characterised as a ‘Highly Vulnerable Development’, the application of the justification test will not be required as it is categorised as **Appropriate**.

### 4.4. Environmental Impact Assessment

At the project or development level, exceeding specified thresholds or development under threshold but with significant environmental effects and in an area at risk of flooding requires Environmental Impact Assessment Report (EIAR). Refer to EIAR chapter 12 Water Environment for detailed assessment.

## 4.5. Conclusion: Stage 2

The purpose of the scoping stage 2 is to identify possible flood risks and to implement the necessary level of detail required to assess these possible flood risks, and to ensure these can be adequately addressed in the FRA. The scoping exercise should also identify that sufficient quantitative information is already available to complete an FRA appropriate to the scale and nature of the development.

The evidence provided in the Stage 2 Assessment (underpinned by the Stage 1 Assessment and the topographic survey assessment) indicates the Site and Proposed Development would not be at fluvial risk from the network of streams flowing nearby. The Galway County Council SFRA indicates the Site lies in Flood Zone C (i.e., at low risk of fluvial flooding). Additionally, the Stage 2 assessment revealed the Site is characterised as 'Highly Vulnerable', and therefore the application of the Justification Test would not be required.

## 5. Stage 3 - Detailed Flood Risk Assessment

Although from stage 1 and stage 2, the overall flood risk assessment can be concluded as Appropriate development, a detailed flood risk assessment is carried out.

### 5.1. Proposed Development

The Proposed Development is a separate facility to the existing Tynagh CCGT Power station. A sufficient drainage system will be provided to connect to the existing power station's surface water drainage systems (there will be no requirement to connect to the Tynagh Power Station existing foul water system as there will be no foul water generated). Refer to the Proposed Development layout and site boundary drawings prepared by Architects and attached as Appendix C.

It is estimated that the total area of the Proposed Development site is approximately 8.30 ha, which will require a comprehensive drainage strategy to accommodate the 1.53 ha hardstanding development located on undeveloped (former mine brownfield) land north of the Tynagh Power Station site. The Proposed Development will consist of a new Open Cycle Gas Turbine (OCGT) plant and all associated ancillary development and connection infrastructure, site works and services. The details of site development are presented in Chapter 5 of the EIAR.

The area which is to be developed is proposed to be to a finished floor level of 67.5 m AOD. The proposed service road between the fuel oil storage and along the periphery of the OCGT stack and related infrastructure will be set at a profile of approximately 67.5m AOD.

### 5.2. Foul Drainage

#### 5.2.1. Existing Foul Drainage

The existing Tynagh Power Station site drainage system (located to the south of the Proposed Development) is a gravity fed system which conveys the foul water from the Power Station building, existing warehouse facility, administration building and gate house towards the eastern boundary of the site where the on-site wastewater treatment plant is located. The gravity system is collected via the existing pumping station which pumps the foul water towards the wastewater treatment system. The existing on-site wastewater treatment system is a Klargester BioDisc unit, sand filter unit and then onto a percolation drainage field located along the eastern boundary of the power station site.

Refer to attached Appendix D – Existing site services and drainage layout.

#### 5.2.2. Proposed Foul Drainage

There are no additional proposed foul drainage associated with the Proposed Development and there is no increase in staffing numbers (i.e. no increase in foul water management requirement).

The Proposed Development will not lead to an increase in staff and therefore there will be no additional foul water generated (either from sanitation or process water) and as a result there will be no requirement for increased foul water management at the site over and above existing facilities.

However ensure longevity in performance, the existing Tynagh Power Station Klargester BioDisc wastewater treatment system (which has been in use for circa 15 years) will be replaced with a Klargester Bioficient 5 system which is suitable to cater the daily allowance. The proposed Bioficient system is of comparable size to the existing system and will operate effectively in conjunction with the existing percolation area.

An assessment of the percolation area has been undertaken for inclusion in the 'Site Characterisation Form' submitted with the Planning Statement (refer to Appendix G of this document). It is determined that the existing drainage field and subsoil percolation rates have sufficient capacity to manage the discharge rates from the whole site foul water demands of 0.0416 l/s (based on 150 l/day for up to 24 people = existing staff).

### 5.2.3. Existing Surface Water Drainage

The existing Tynagh Power station site drains via runoff in line with the engineered falls of the site. The drainage drains from west to east. Refer to the Topographical Survey information attached in Appendix B. From a detailed review of survey and as-built information, the site infrastructure information indicates that the surface water sewer connects south into the wider drainage infrastructure for the existing power station. GPR surveys and as-built information have identified the location of manhole chamber covers for all services (foul and surface) under the road layout and are included in Appendix D.

The site-wide drainage system drains towards the southeast of the site where the surface water discharges into the lagoon at an invert level of 60m AOD. It is assumed that the current drainage system discharges into the lagoon at an unrestricted discharge rate.

In the northern section of the power station site, the undeveloped gravelled land is presumed to rely on drainage from infiltration into the ground and the flow of overland water east into an open ditch bordering the site on the east. The information gathered indicates that the area of land to the west of the site and directly in front of the entrance to the power station historically has been susceptible to overland flooding from the southwest.

The total area of the Proposed Development site is a combination of brownfield and industrial land. Presently, the lands to the north of the existing Tynagh Power Station does not have surface water drainage infrastructure. Undeveloped brownfield land has a gravelled surface and is assumed to be drained from infiltration into the ground. Greenfield land is assumed to have natural infiltration into the ground.

### 5.2.4. Proposed Surface Water Drainage

The proposed surface water drainage strategy considers the change in land use. The undeveloped land will now accommodate OCGT, stack, air intake, fin fan coolers, fuel oil storage, fuel treatment, service road etc. As this site will be changing from a greenfield site to an impermeable brownfield site, associated hydraulic design is required to mitigate the impact on the capacity of the existing site-wide sewer infrastructure of the power station. A suitable drainage network shall be provided to connect to the existing drainage infrastructure of Tynagh power station. Therefore, for the 1.53 ha of hardstanding area, a below-ground drainage strategy has been developed to show how surface water will be managed before it is connected to the current power station drainage system.

The proposed surface water drainage strategy is based on keeping equivalent peak discharge rate from developed impermeable area to existing greenfield runoff conditions. The peak discharge rate will be based on 1 in 100-year storm event, with the inclusion of a climate change factor additional allowance of rainfall intensity. As a conservative approach, 30% climate change allowance has been considered at this stage.

The surface water drainage will be a positive system (gullies, pipes) and need to be attenuated through below ground storage at a restricted rate. To achieve this, a flow control device, a petrol interceptor for the treatment of any contaminated water from vehicles shall be provided.

There is surface water network provision within the Tynagh power station, as demonstrated in the record drawings. The drainage proposal will ensure that the development site is suitably drained into the existing power station site wide network via gravity. The final discharge point is proposed to be connected can be referred to in Appendix E, the proposed drainage layout. A suitable sized drainage network will be provided for the access & service road drainage with a final chamber to connect into the existing site-wide drainage system.

#### 5.2.4.1. Preliminary Calculation:

The sufficient attenuation area will be provided within the site for storms in excess up to and including the 1 in 100-year storm plus 30% climate change event to ensure there is no flooding of development area, on or off the site. This should be further investigated in detailed design stage.

Overland flow routing exceeding the 1 in 100 years plus 30% climate change storm event should direct flows to a common area within the site having flood depth not exceeding 100mm to ensure access or egress is unrestricted at all times. Checks should also be made to ensure no flooding of properties occur within the site during this scenario.

For the purpose of this detailed drainage assessment; greenfield run-off rates, discharge rate and the attenuation volume required to store the 100-year storm (+ 30% climate change) was calculated using H.R. Wallingford online tool.

### Greenfield run-off rate estimation

Greenfield Run-off rate calculations are based on H.R. Wallingford Greenfield runoff rate estimation online tool (UKSuDS.co.uk), refer to Appendix F. Figure 14 clipping below extracted from final results of the runoff rates shows 2.81 l/s for 1 in 100-year time.

Greenfield runoff rates	Default	Edited
Q <sub>BAR</sub> (l/s):	1.44	1.44
1 in 1 year (l/s):	1.23	1.23
1 in 30 years (l/s):	2.38	2.38
1 in 100 year (l/s):	2.81	2.81
1 in 200 years (l/s):	3.1	3.1

Figure 14: Clipping from Greenfield run off rate report – (Source: HR Wallingford Online tool)

### Surface water storage volume estimation

The HR Wallingford FEH Statistical tool was used to pre estimate the storage volume requirements, refer to Appendix F. This tool is not suitable for detailed design of drainage systems. It is recommended that hydraulic modelling software -Microdrainage Source Control shall be used to calculate volume requirements and final drainage layout prior to construction.

The proposed site will cover a total area of 8.30 ha with impermeable area approximately 1.53 ha including hardstanding and service roads (proposed layout included as Appendix C). The impermeable area (1.53 ha) was set at 100% of the overall.

Best practice has shown that where flow rates are less than 5.0 l/s consent for discharge is usually set at 5.0 l/s if blockage from vegetation and other materials is possible.

The tool gives a total storage volume requirement for the proposed strategy of approximately 1468m<sup>3</sup> illustrating in Figure 15 below. The storage can be provided by means of oversized pipework/ manhole chambers and/or attenuation tank. Refer to the drainage layout plan which illustrates how the 1468m<sup>3</sup> of below ground granular storage will be formed as part of the existing drainage network. This will provide the main storage requirements for the site along with source control and lever of water quality treatment prior to discharging offsite.

Site discharge rates	Default	Edited	Estimated storage volumes	Default	Edited
1 in 1 year (l/s):	5	5	Attenuation storage 1/100 years (m <sup>3</sup> ):	1468	1468
1 in 30 years (l/s):	5	5	Long term storage 1/100 years (m <sup>3</sup> ):	0	0
1 in 100 year (l/s):	5	5	Total storage 1/100 years (m <sup>3</sup> ):	1468	1468

Figure 15: Surface water storage (Source: HR Wallingford Online tool)

Additionally, flood alleviation provision shall be provided by through a raised plateau at the site access (Tynagh power station) along with concrete upstand supports for the fence to act as a barrier should any ingress be encountered from outside the site. Refer to drawing 60661667-SHT-0-2000-DRAINAGE LAYOUT in Appendix E for proposed drainage layout.

## 5.3. Mitigation Measures

A total maximum storage volume of 1468m<sup>3</sup> and 5.0 l/s discharge rates has been hydraulically modelled using H.R. Wallingford surface water storage volume estimation online tool. The calculated storage and discharge can be achieved by a combination of the following:

- Volume of traditional drainage system components i.e. pipes and manhole/catchpit chambers.
- Underground attenuation storage with volume control flow system to release storm water in safe manner to a suitable discharge location to the watercourse.
- Provision of attenuation measures to reduce the peak surface water discharge rates by proposing minimum 300mm free board within manhole network.
- Flow control device on storage volume outflow; orifice plate, Hydrobrake or Hydroslide to achieve 5.0 l/s controlled discharge rate into receiving drainage infrastructure.
- Robust maintenance management regime to ensure the performance of the below ground drainage system is sustained for its intended design life.
- The proposed building FFL shall be designed so that the ground falls away from the building. Consideration must be given where unavoidable adjacent ground which falls toward building shall be diverted away while drainage designing.



## 6. Conclusion

AECOM has prepared this document to support the planning submission and Environmental Statement and to assess the drainage adequacy of the Proposed Development.

From stage 1, the Flood Risk Identification concludes that:

- The Proposed OCGT site is not in the fluvial flood zone of Kilcrow River or near the vicinity of any other river or watercourse.
- The existing Tynagh CCGT site has a positive drainage network system (foul + surface) and is connected to an on-site wastewater treatment plan. The final discharge is connected to the lagoon. The embankment surrounding the lagoon prevents overland flooding
- Historical flood events at the CCGT site indicate they were caused by a prolonged period of rainfall. Mitigation measures have been implemented since the flood occurred.
- The topography of the Proposed Site indicates groundwater would flow away from the Proposed Site.

From stage 2, the Initial Flood Risk Assessment concludes that:

- According to the Planning System and Flood Risk Management guidelines set for planning authorities, the proposed site falls under highly vulnerable development under determination of vulnerability class.
- Under determination of flood zone, it is classified as Flood Zone C i.e., the probability of flooding from watercourses and the sea is low or negligible (less than 0.1% or 1 in 1000 year for both watercourse and coastal flooding).
- According to the justification table provided in the guidelines, the proposed development is categorised as Appropriate.

From stage 3, the Detailed Flood Risk Assessment concludes that:

- The surface water run-off from the ground-level hardstanding will be routed to the existing surface water drainage infrastructure of CCGT power station.
- The proposed surface water discharge rate will be equivalent to the greenfield run-off rate. However, in order to avoid blocking the network by vegetation, the flow rate is set at 5.0 l/s with a storage volume of approximately 1465m<sup>3</sup>.
- The mitigation measures will be implemented in the form of underground geocellular storage and hydrobrakes or similar systems that control the flow rate.

With regard to Foul Water Management:

- The Proposed Development will not lead to an increase in staff and therefore there will be no additional foul water generated (either from sanitation or process water) and as a result there will be no requirement for increased foul water management at the site over and above existing facilities.
- However ensure longevity in performance, the existing Tynagh Power Station Klargester BioDisc wastewater treatment system (which has been in use for circa 15 years) will be replaced with a Klargester Bioficient 5 system which is suitable to cater the daily allowance.
- The proposed Bioficient system is of comparable size to the existing system and will operate effectively in conjunction with the existing percolation area.
- An assessment of the percolation area has been undertaken for inclusion in the 'Site Characterisation Form' submitted with the Planning Statement (and Appendix G of this report). It is determined that the existing drainage field and subsoil percolation rates have sufficient capacity to manage the discharge rates from the whole site foul water demands.

# Appendix A

## A.1 Site Location

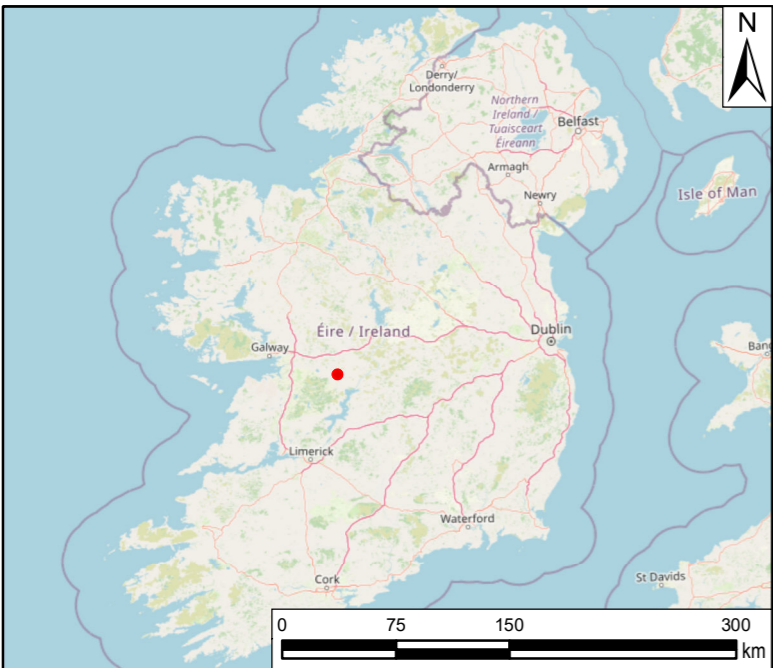

THIS DRAWING IS TO BE USED ONLY FOR THE PURPOSE OF ISSUE THAT IT WAS ISSUED FOR AND IS SUBJECT TO AMENDMENT

**LEGEND**  
 Proposed Development Site

Notes:  
 Copyright: © OpenStreetMap (and) contributors, CC-BY-SA  
 Source: Esri, Maxar, Earthstar Geographics, and the GIS User Community

Purpose of Issue:  
**ENVIRONMENTAL IMPACT ASSESSMENT REPORT (EIAR)**

Client:  
**EP Energy Developments**

Project Title:  
**TYNAGH NORTH OCGT**

Drawing Title:  
**SITE LOCATION**

Drawn: TS	Chk'd: JB	App'd: POC	Issue: August 2023
AECOM Internal Project No: 60661667		Scale at A3: 1:2,000	

THIS DOCUMENT HAS BEEN PREPARED PURSUANT TO AND SUBJECT TO THE TERMS OF AECOM'S APPOINTMENT BY ITS CLIENT. AECOM ACCEPTS NO LIABILITY FOR ANY USE OF THIS DOCUMENT OTHER THAN BY ITS ORIGINAL CLIENT OR FOLLOWING AECOM'S EXPRESS AGREEMENT TO SUCH USE, AND ONLY FOR THE PURPOSES FOR WHICH IT WAS PREPARED AND PROVIDED.

AECOM  
 4th Floor, Adelphi Plaza, George's Street Upper  
 Dun Laoghaire  
 Co. Dublin, A96 1927  
 +353 (1) 238 3100  
 www.aecom.com



Drawing No:  
**FIGURE 1.1**

Rev:  
**0**

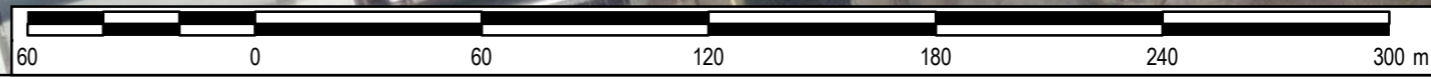

File Name: \\na.aecomnet.com\fs\ENEA\Dublin\IEDBLZ\Legacy\DU-MAN-002\Data\Co\Dublin\Jobs\GIS\60661667\_Tynagh\_OCGT\_North\GIS\02\_Maps\Chapter 1 - Introduction\Figure 1.1 - Site Location\_Aerial\_20230802.mxd

# Appendix B

## B.1 Existing Site Topographical Survey

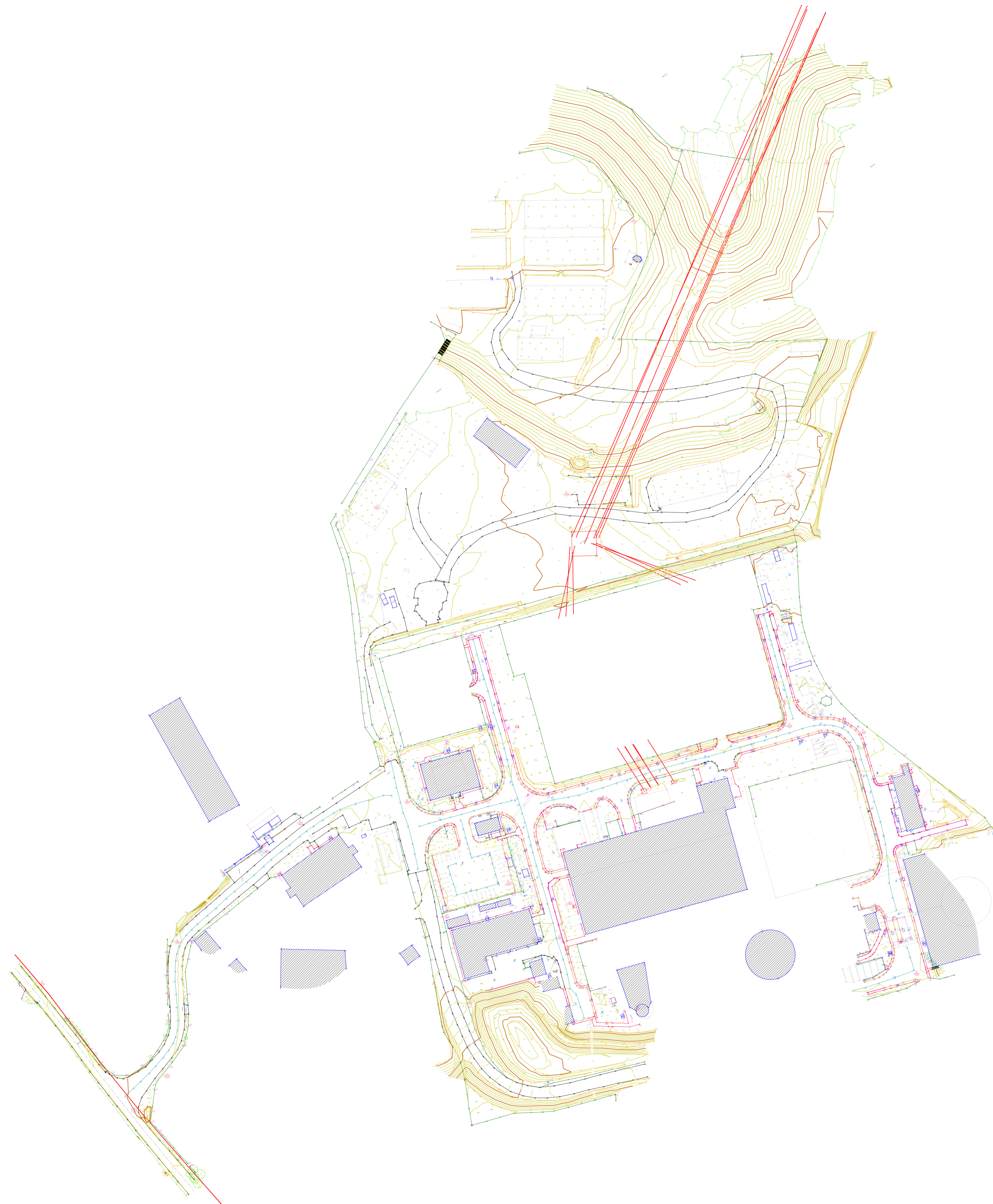
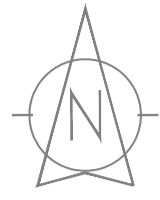

**LEGEND**  
Street furniture & Services

Over Head Wires (LUAS) - Pylon ESB	Bus Stop	Road Sign	Phone Box
Flowerbed	Ballast	Bench Seat	Dust
Pipe	Beacon	Keok	Gas Cover
Lit	Coalhole Cover	Gully	CP Flow
Barrier	Bore Hole	Waste Bin	US Car Park Vent
Pump	Electricity Pole	Hydrant	Fire Hydrant
Bus/Tram Shelter	Telegraph pole	Fire Hydrant	Fire Hydrant
Postbox	OCS Pole	ESB Box	ESB Box
Water - General	CCTV Camera Pole	ESB Inspection Cover	ESB Inspection Cover
Water Valve	Lamp Post	Traffic Control Box	Traffic Control Box
Gas Valve	Foul Manhole	LUAS Technical Cubicle	LUAS Technical Cubicle
Sluice Valve	Surface Water MH	Ticket Vending Machine	Ticket Vending Machine
Air Valve	Manholes	Water Meter Cover	Water Meter Cover
Stop Cook	Air Conditioning Vents	Telecom Inspection Cover	Telecom Inspection Cover
C/P Post	Services Inspection Cover	Monument / Toilets	Monument / Toilets
Marker Post	Traffic Inspection Cover	Tank Storage	Tank Storage
Traffic Light	Cable TV Inspection Cover	Basement MH Cover & Pipe	Basement MH Cover & Pipe
Parking Meter	ESAT Inspection Cover	Defined Aerial Mark	Defined Aerial Mark
Flare Asset Mark	NFL Inspection Cover	Stay for pole	Stay for pole
Smart Card Validator	EScom Inspection Cover	PP	Pipe Protection
Unknown Valve	Rocking Eye	Washout	Washout

**Natural Features**

Surface Change	Water Level	Golf
Land Drain	Crown Level	Fall Way
Bottom of Slope	Invert Level	Green
Top of Slope	Bed Level	Tree Box
Ditch	Spotheight	Other
Water Edge / Lake / Pond		Survey Station
Hedge / Trees Drip Line / Vegetation		Photo point
Tree Coniferous	Tree Deciduous	Top of Tree

**Built Features**

**Roads & Road Markings**

Building	Fence	Floor Level
Edge of Road	Gate	Apex Height
Kerb Bottom	Road Centreline	Eaves Height
Kerb Top	Top of Wall	Parapet Height
Bridge Abutment	Hoarding	Soffit Elevation
Bridge Deck	Property Line	Step Level
Bridge Parapet	Road Sloar	Concrete Pad
Building Facade	Top of Fence	Track
Footpath / Platform Train & Tram	Wall / Retaining Wall	
Damp Proof Course / Veige	Railway / Tram Rail / Grating / Ramp	
Bridge Pier / Wall & Gate Pier / LUAS Trackbed	Building Canopy / Roof / Overhang	
Cycleway / Private Landing Area		

Murphy Surveys Ltd. Disclaimer

The user or recipient of this survey data understands and acknowledges this data may be inaccurate or contain errors or omissions and the user or recipient assumes full responsibility for any risks or damages resulting from: arising from, or in connection with any use of or reliance upon data displayed herein. Although significant care has been exercised to produce surveys that satisfy survey accuracy standards, these surveys are only as accurate as the source data from which they were compiled. Although all reasonable steps have been taken to locate all features visible at the time of the survey, there is no guarantee that all will be shown on the drawing, as some above ground features may have obstructed the survey. Wherever possible, areas unable to be surveyed will be labelled as "UTS".

The Company shall not be liable for any inaccuracy of the data provided beyond the specified scale or accuracy, or for any matters resulting from their use for purposes other than that stated in the Contract. No liability shall attach to the Surveyor in respect of any consequential loss or damages suffered by the Client.

The Client must promptly notify the Company of any errors in mapping of which it becomes aware. If misleading, inaccurate or otherwise inappropriate information is brought to the Company's attention or the Company itself identifies any such imprecision or error in a survey, it shall use its reasonable endeavours to fix or remove it and if necessary in certain instances, the Company being on notice of any such misleading, inaccurate or otherwise inappropriate information, it will re-conduct the survey and reproduce the data to within the specified scale or accuracy.

Site Location

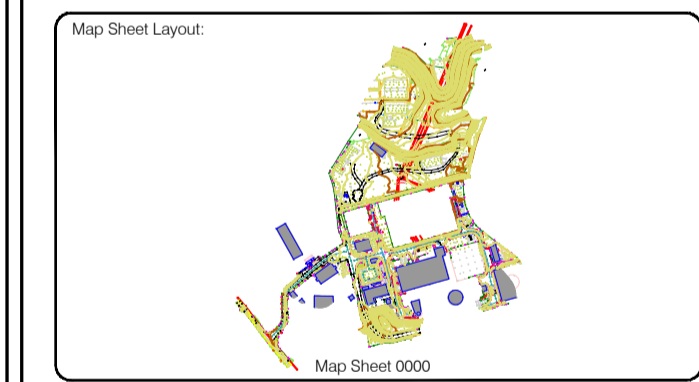
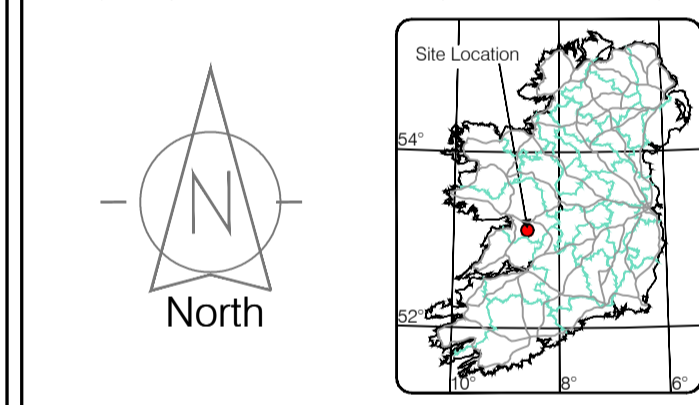

Surveyed by: BT	Date: JULY 2021	Datum: Main Head
Drawn by: CD	Date: JULY 2021	Grid System: Irish National Grid
Checked by: PK	Date: 23.07.2021	Irish National Grid: ITM

No.	Date	Description	Revisors
0	23.07.2021	Field Drawing	



Topographic surveys, Measured Building Surveys, Setting-out, As-Built Surveys, Hydrographic Surveys, Legal Mapping, Pipeline Surveys, Service Location, Ground Penetrating Radar, Laser Scanning, Aerial Photography

Kildare Cork Dublin Belfast Glasgow Manchester London

**Head Office**  
Global House  
Kilcullen Business Campus  
Kilcullen Co. Kildare, Ireland

Phone: (+353) 045 484040  
Fax: (+353) 045 484004  
Email: info@murphyge.ie

<b>Client :</b>	AECOM
<b>Project :</b>	Tynagh Power Station Topo
<b>Date :</b>	23.07.2021
<b>Scale :</b>	NTS@A1
<b>Description :</b>	Topographical Survey
<b>Drawing Number :</b>	MGL42168_T_ITM_Rev0-00

© Copyright 2021 MURPHY GEOSPATIAL LTD

# Appendix C

## C.1 Proposed Layout Plan

NORTH

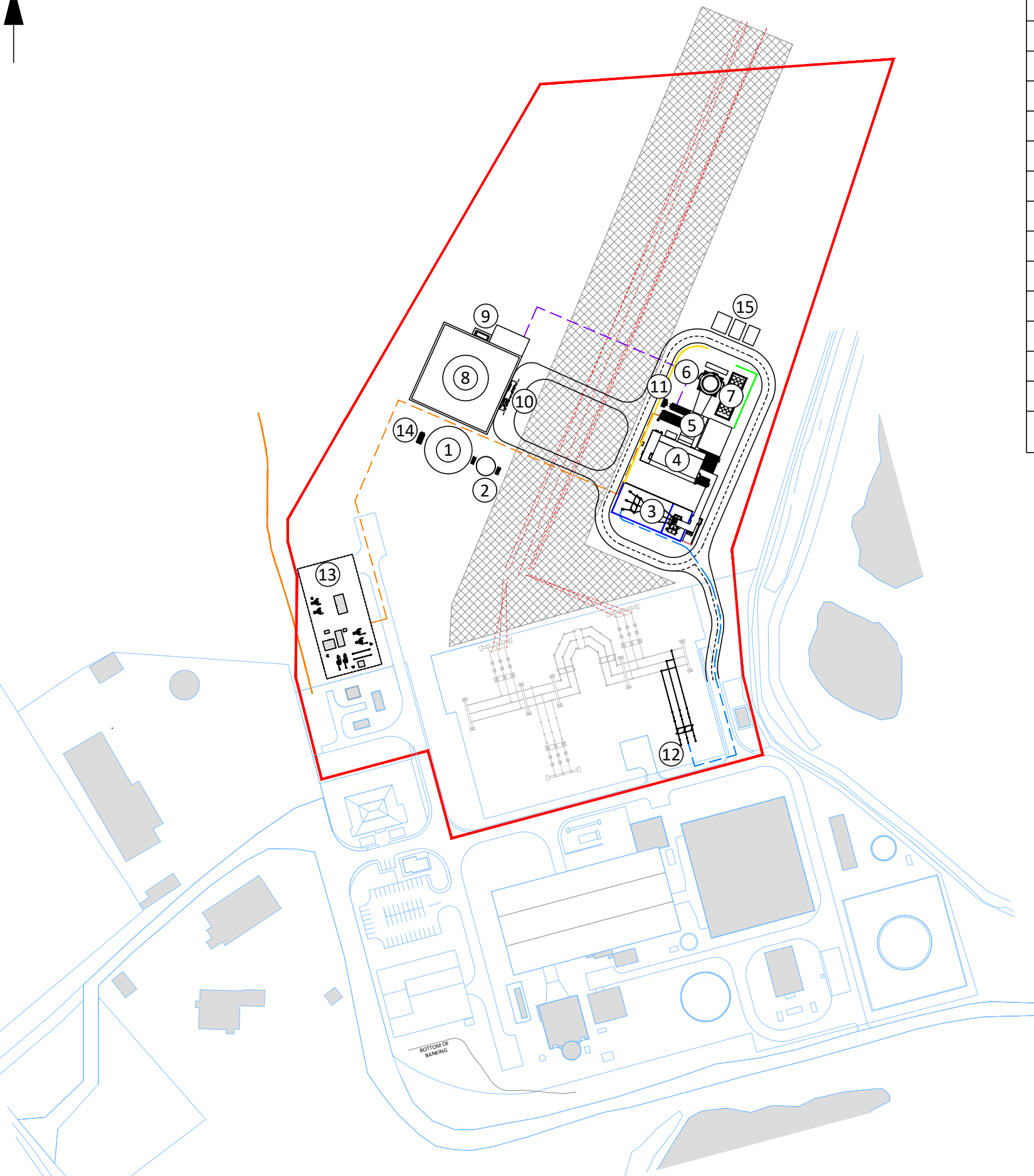

REF	DESCRIPTION
1	DEMIN TANK
2	FIREWATER TANK & PUMPHOUSE
3	SWITCHYARD
4	AIR INTAKE
5	OCGT
6	STACK
7	FIN FAN COOLERS
8	FUEL OIL STORAGE
9	FUEL TREATMENT
10	FUEL UNLOADING BAY
11	PROPANE STORE
12	NEW 220kV SWITCHYARD BAY
13	AGI
14	EMERGENCY DIESEL GENERATOR
15	LUBRICATION OIL AND CHEMICAL STORES

ALL INFORMATION ON THIS DRAWING MAY BE SUBJECT TO FURTHER DESIGN DEVELOPMENT.

**DO NOT SCALE**

**LEGEND**

- OHL OHL OVERHEAD LINES
- EXISTING GAS LINE
- REDLINE BOUNDARY
- PROPOSED FUEL OIL SUPPLY
- PROPOSED GAS SUPPLY FROM AGI TO OCGT (BELOW GROUND) C.257m
- PROPOSED HV CABLE ROUTE
- INDICATIVE EASEMENT AROUND HV CABLES
- ACOUSTIC BARRIER 7m HIGH
- ACOUSTIC BARRIER 10m HIGH
- ACOUSTIC BARRIER 8m HIGH

REV.	DETAILS OF REVISION	DRAWN	CHKD	APR	DATE
R8.0	AMENDED FOLLOWING CLIENT COMMS	DTW	AO1	LM2	02.08.23
R7.0	AMENDED FOLLOWING CLIENT COMMS	DTW	AO1	LM2	31.07.23
R6.0	AMENDED FOLLOWING CLIENT COMMS	DTW	AO1	LM2	28.07.23
R5.0	SWITCHYARD & AGI ADDED	DTW	AO1	LM2	27.07.23
R4.0	NATURAL GAS PIPE AMENDED	DTW	AO1	HHE	23.01.23
R3.0	ACOUSTIC BARRIERS ADDED	DTW	AO1	LM2	05.01.23
R2.0	PRELIMINARY	DTW	AO1	LM2	22.12.22
R1.0	PRELIMINARY	DTW	AO1	LM2	15.12.22

**FICHTNER**  
 CONSULTING ENGINEERS LIMITED  
 77 Sir John Rogerson's Quay, Block C,  
 Grand Canal Docklands,  
 Dublin 2, D02 VK60  
 Tel: +353 (1)506 0632  
 Website: www.fichtner.ie

CLIENT: EPED

SITE: TYNAGH NORTH

PROJECT: TYNAGH NORTH

TITLE: OCGT PLAN

DRAWING STATUS: PRELIMINARY	
DRAWN BY: DTW	DATE: 09.08.22
CHECKED BY: AO1	DATE: 09.08.22
APPROVED BY: LM2	DATE: 09.08.22
FILENAME: S3577-8310-0001DW OCGT PLAN R8.0	
OFFICE OF ISSUE: DUBLIN	
SHEET SIZE: A3	SCALE: 1:2500

DRAWING No.: **S3577-8310-0001** Sheet 1 of 1 REVISION: **R8.0**

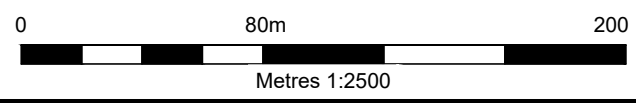

# **Appendix D**

## **Record Drawings of Existing Tynagh Power Station**

### **D.1 Existing services Layout**

### **D.2 Storm Water Drainage layout**

### **D.3 Sanitary Services and Drainage Layout**

### **D.4 Sewage Treatment Plant Layout**



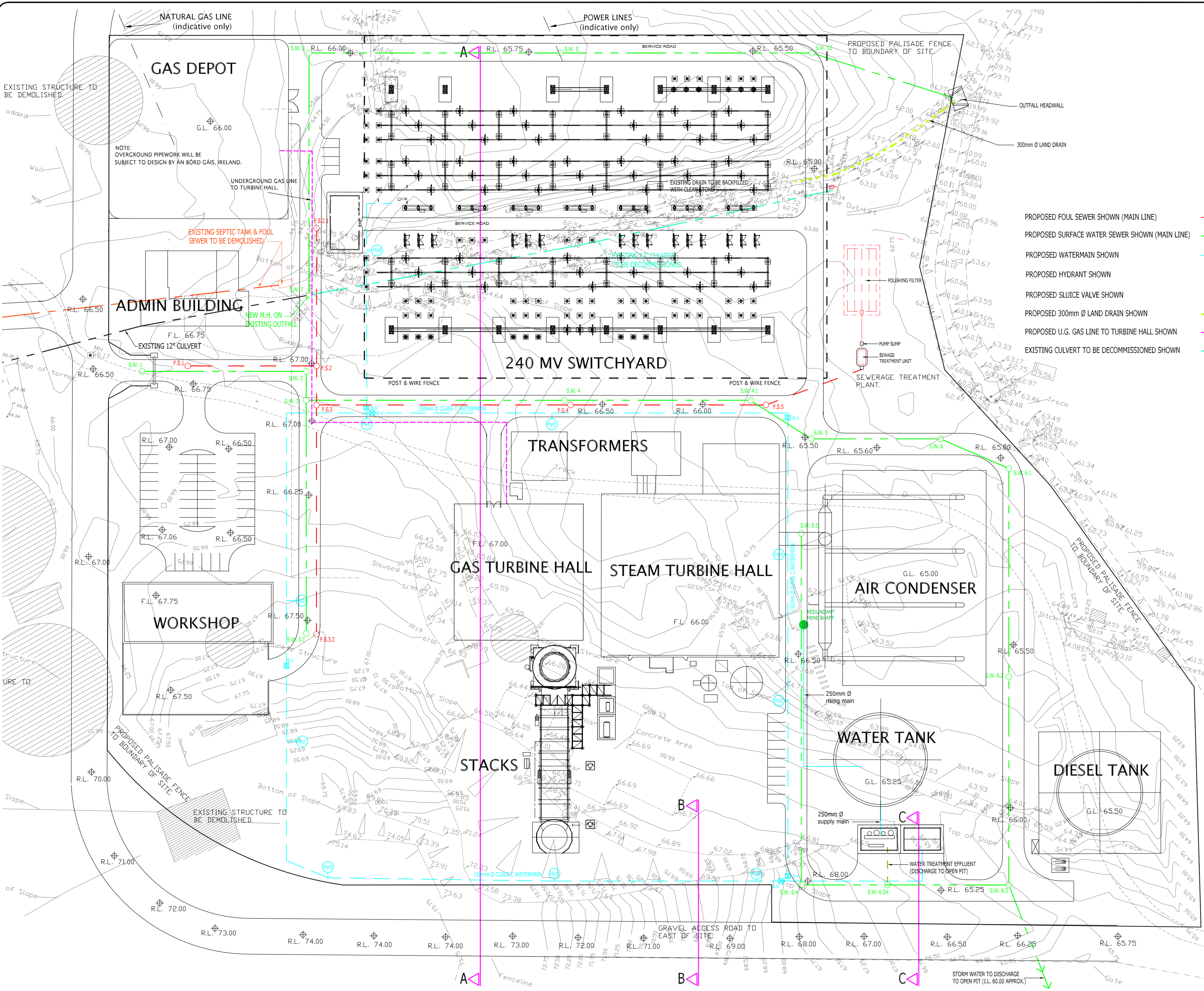

Notes

Revision	Description	Date
A	Development repositioned, sewer layout revised	3/4/03

Client: MOUNTSIDE PROPERTIES LTD.

Job title: PROPOSED POWER STATION AT TYNAGH MINES, TYNAGH, CO. GALWAY

Drawing title: SERVICES LAYOUT

Drawn By: S.H. Date: 14/03/03 Checked By: Date:   
 Approved By: Date: Status: PLANNING

Job No: 01072

Drawing No: C-P-01 Revision: A

Drawing Scale: 1/500

**HGL O'CONNOR**  
 Consulting Civil & Structural Engineers  
 HGL O'Connor + Company  
 Wood Quay Court, Wood Quay, Galway, Ireland  
 Tel (091) 563191 Fax (091) 568683  
 e-mail mail@hgl.ie

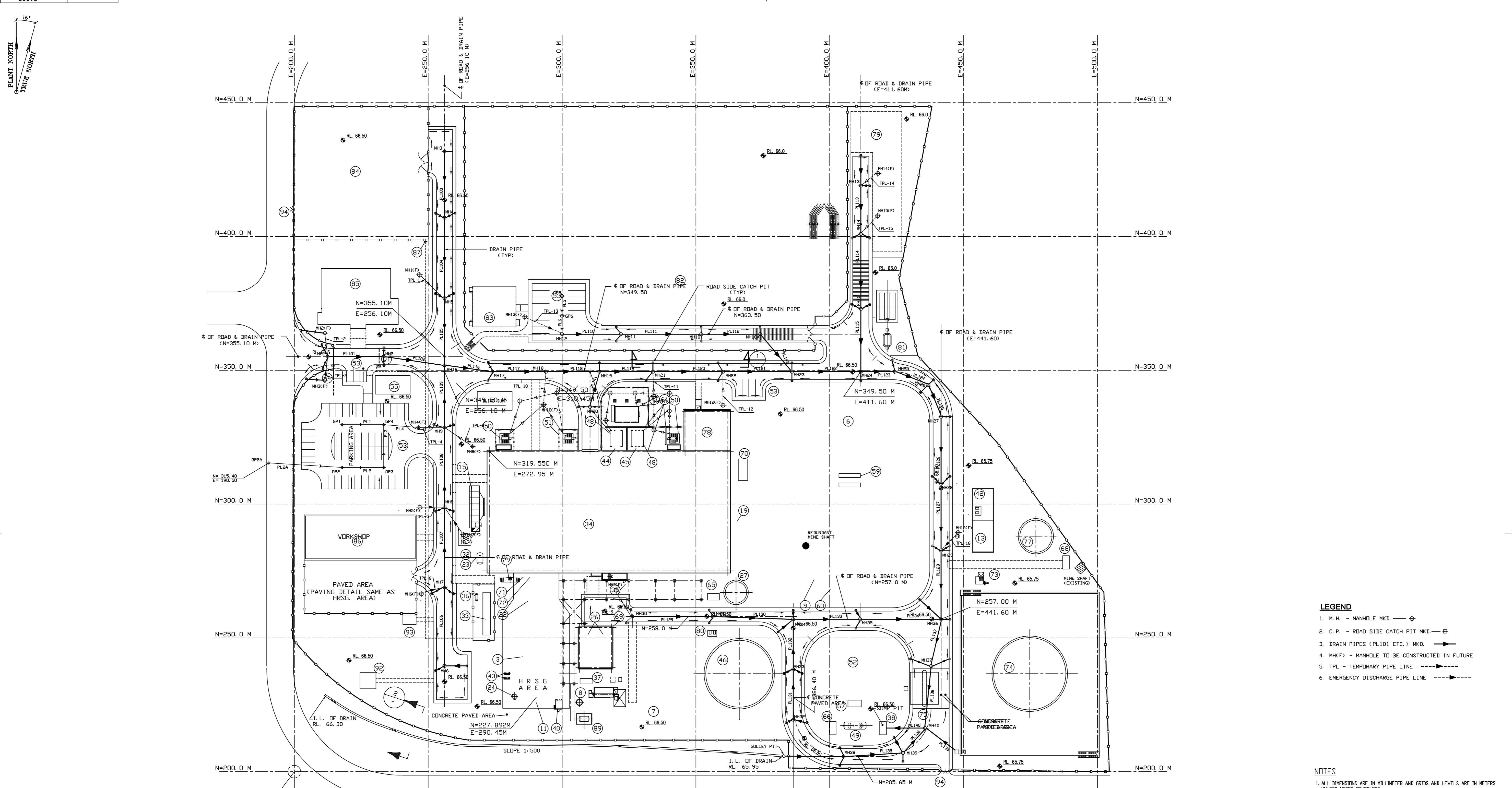

NATIONAL GRID X=174373.499 M  
Y=212766.731 M

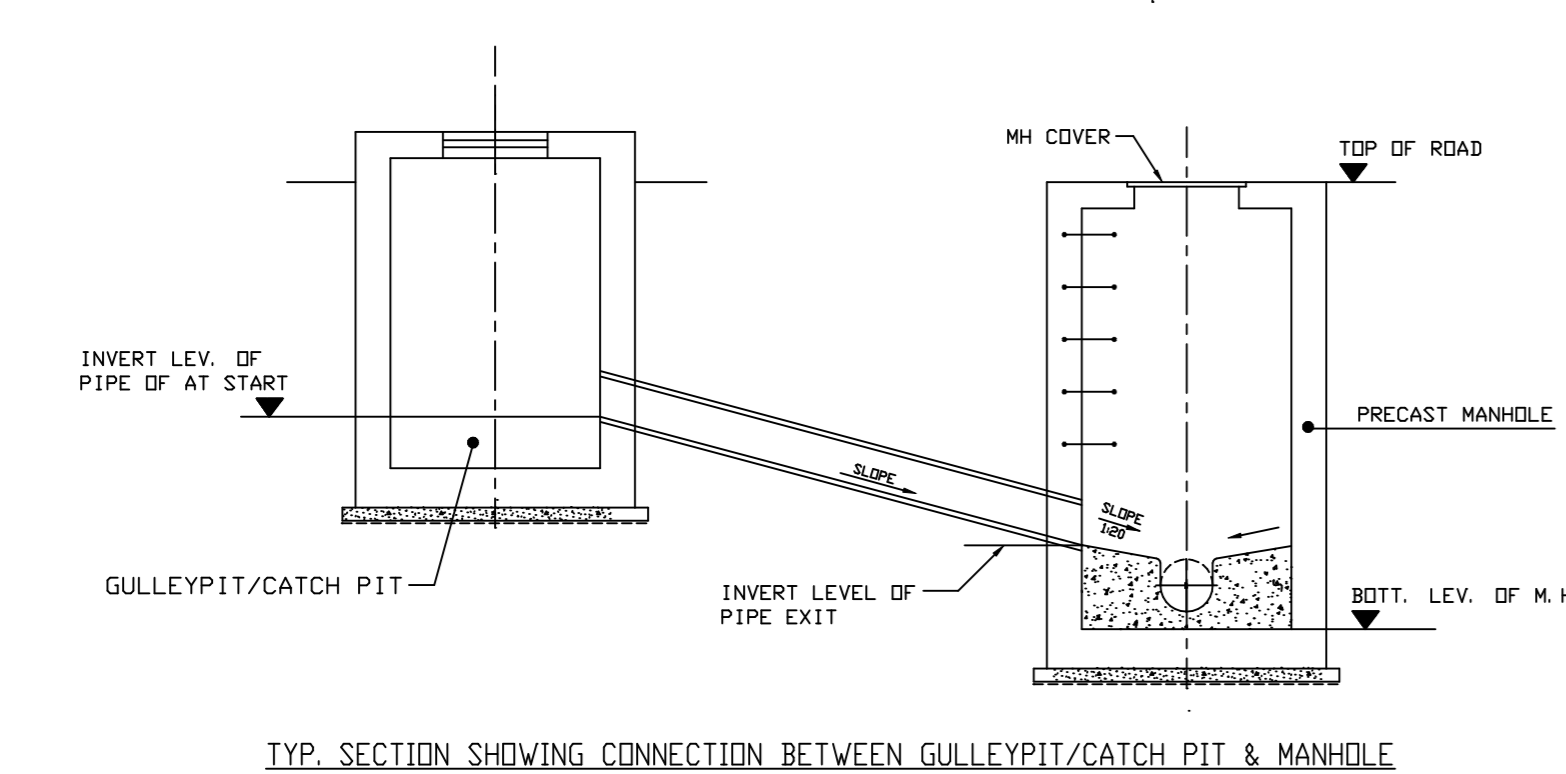

TYP. SECTION SHOWING CONNECTION BETWEEN GULLEYPIT/CATCH PIT & MANHOLE

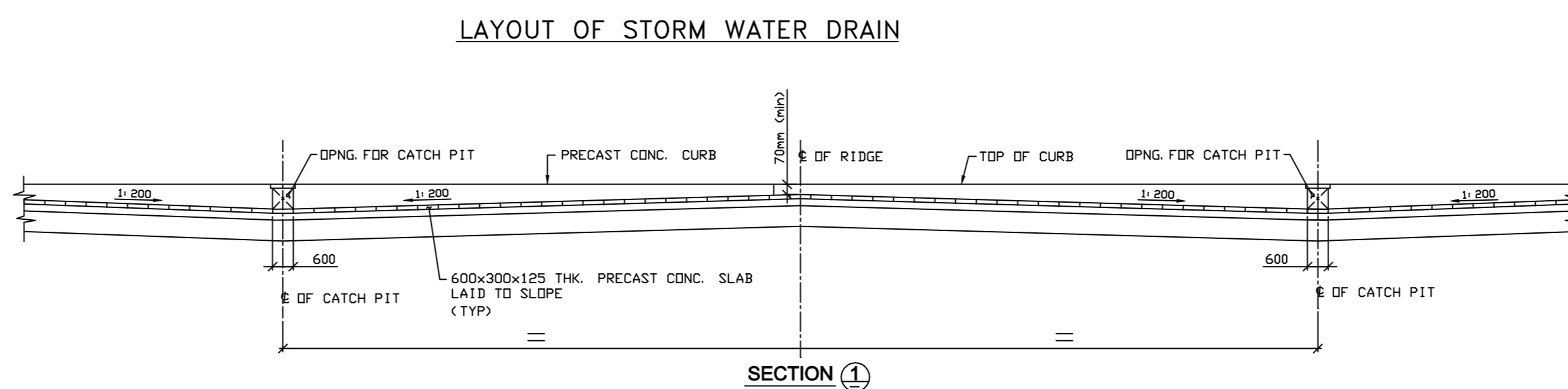

SECTION 1  
(SHOWING TYPICAL ARRANGEMENT OF PRECAST CONC. SLAB AT EDGE OF ROAD)

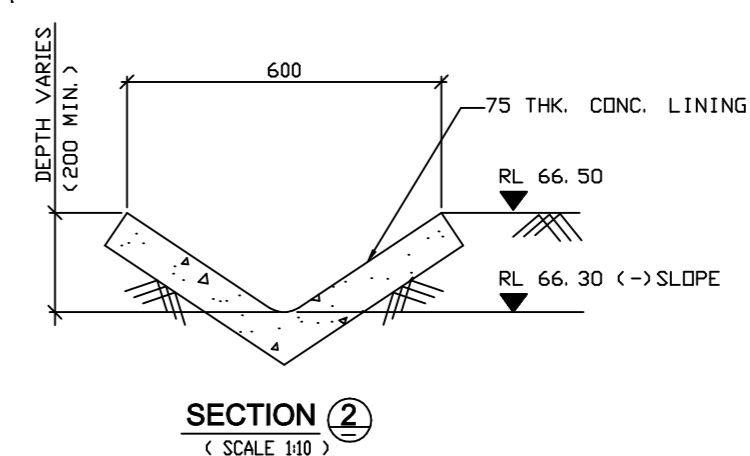

SECTION 2  
(SCALE 1:10)

- LEGEND**
- M.H. - MANHOLE MKD. — ⊕
  - C.P. - ROAD SIDE CATCH PIT MKD. — ⊕
  - DRAIN PIPES (PL101 ETC.) MKD. — →
  - MHKF - MANHOLE TO BE CONSTRUCTED IN FUTURE
  - TPL - TEMPORARY PIPE LINE - - - - -
  - EMERGENCY DISCHARGE PIPE LINE - - - - -

- NOTES**
- ALL DIMENSIONS ARE IN MILLIMETER AND GRIDS AND LEVELS ARE IN METERS UNLESS NOTED OTHERWISE
  - ALL GRIDS ARE BASED ON PLANT GRID COORDINATES
  - ALL LEVELS SHOWN AS RL ARE RELATIVE TO D.S. DATUM
  - FOR DETAILS OF MANHOLES REFER DWG NO C-1009
  - FOR SCHEDULE OF MANHOLE & DRAINAGE SYSTEM REFER DWG NO C-1008 (SHT 2)
  - LOCATIONS OF MANHOLE MKD. MH (F) ARE TENTATIVE. ACTUAL LOCATION SHALL BE DECIDED AFTER FINALISATION OF NEAR BY BUILDING STRUCTURE/ EQUIPT. FOUNDATIONS.

- REFERENCE DRAWINGS:**
- PLAT DRAWING NO. P001
  - SLOPE STABILIZATION, EROSION AND SEDIMENTATION CONTROL PLAN, SECTIONS & DETAILS DWG NO. C 1003, SHEET 1 OF 2 & SHEET 2 OF 2
  - SITE GRADING PLAN & SECTION DWG NO. C 1002, SHEET 1 OF 2 & SHEET 2 OF 2
  - PLANT FENCING DWG NO. C 1006
  - PLANT ROAD DWG NO. C 1005
  - PLANT SEWERS, CULVERT DITCHES & MANHOLES DWG NO. C 1009.

OWNER **TYNAGH ENERGY LIMITED**  
PROJECT: **400MW COMBINED CYCLE POWER STATION**  
TYNAGH, CO. DUBLIN, IRELAND

PRILIMINARY		DATE		SCALE	
SIGNATURE	DATE	24.05.04	PD	1:500	
ARCHITECT	DATE	21-05-04			
CHKD ADG/SPM	DATE	22-05-04			
PASSED	DATE				
APPRD BB/DG	DATE	24-05-04			

EPIC CONTRACTOR **GE ENERGY**  
SPECIAL SERVICES COMPANY  
SARASOTA, FL, U.S.A.

ARCHITECT **THE KULJIAN CORPORATION**  
ENGINEERS, ARCHITECTS, CONSULTANTS  
PHILADELPHIA, PA, U.S.A.

**TITLE**  
STORM WATER DRAINAGE

JOB NO. **K-3953** DRAWING NO. **C1008** SHEET 1 OF 1

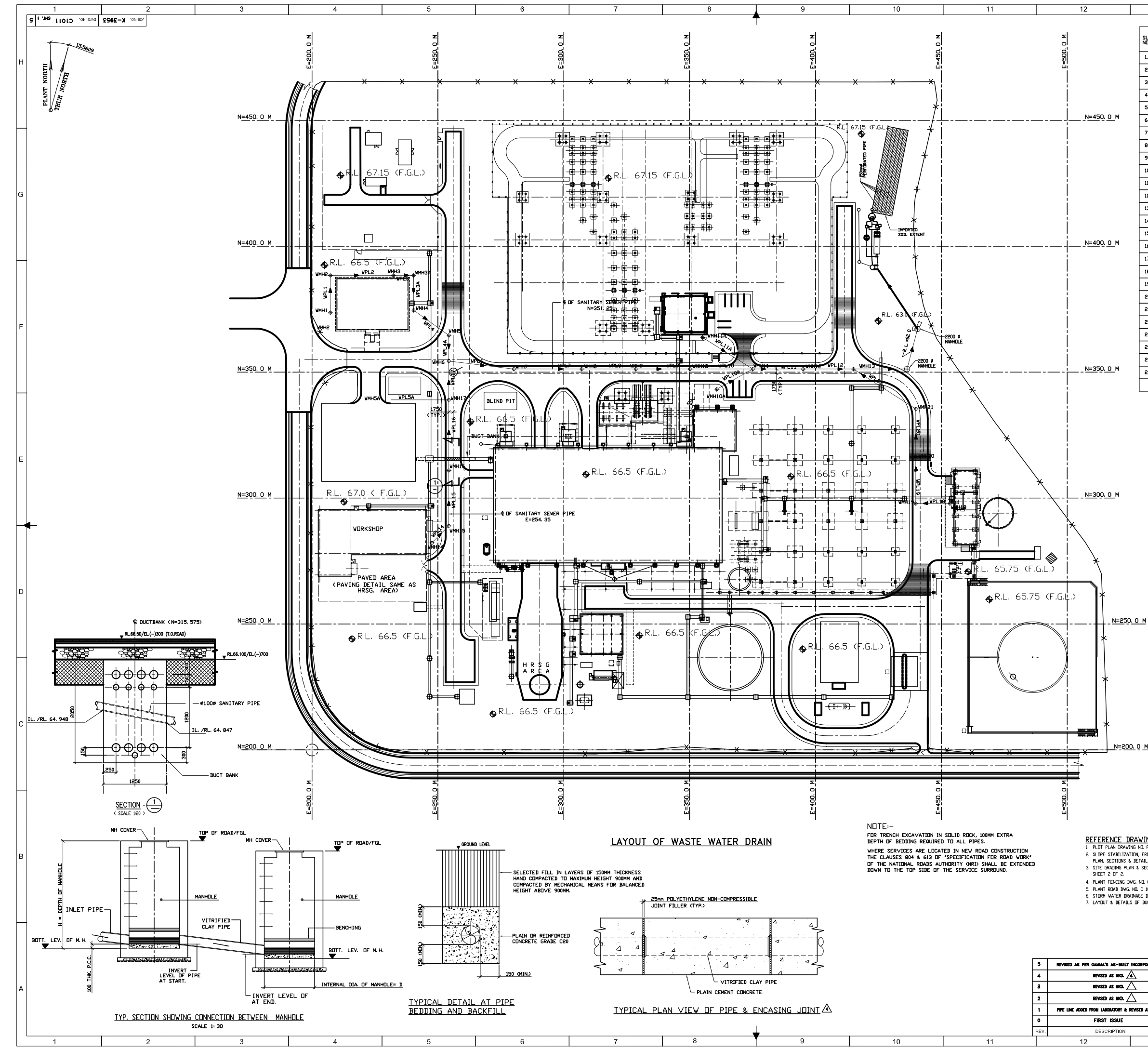

**SCHEDULE OF MANHOLE**

SL. NO.	MANHOLE MKD.	LOCATION	INTERNAL DIA. OF MANHOLE (Ø) (MM)	DEPTH OF ROAD TOP/F.G.L. (MM)	DIA. OF MANHOLE OPENING (Ø) (MM)	TOP OF MANHOLE R.L.	REMARKS
1.	V.M.H.1	373.60 207.30	1200	1110	600	66.5	SEE NOTE 6
2.	V.M.H.2	388.40 207.30	1200	1360	600	66.5	SEE NOTE 6
3.	V.M.H.3	388.40 232.30	1200	1785	600	66.5	SEE NOTE 6
4.	V.M.H.3A	388.40 240.36	1200	1925	600	66.5	SEE NOTE 6
5.	V.M.H.4	374.60 240.36	1200	2160	600	66.5	SEE NOTE 6
6.	V.M.H.5	364.60 254.35	1200	2415	600	66.465	
7.	V.M.H.5A	339.00 230.85	1200	1890	600	66.5	SEE NOTE 5
8.	V.M.H.5B	NOT USED					
9.	V.M.H.6	354.4 254.35	1200	2590	600	66.465	
10.	V.M.H.7	351.25 280.10	1200	2860	600	66.465	
11.	V.M.H.8	351.25 307.10	1200	3145	600	66.465	
12.	V.M.H.9	351.25 328.60	1200	3375	600	66.465	
13.	V.M.H.10	351.25 350.10	1200	3600	600	66.465	
14.	V.M.H.11	351.25 375.10	1200	3865	600	66.465	
15.	V.M.H.12	351.25 395.10	1200	4075	600	66.465	
16.	V.M.H.13	351.25 415.10	1200	4290	600	66.465	
17.	V.M.H.10A	343.200 360.800	1200	2400	600	66.5	SEE NOTE 6
18.	V.M.H.11A	363.80 355.20	1200	1950	600	67.15	SEE NOTE 6
19.	V.M.H.14	282.25 247.60	1200	1035	600	66.465	SEE NOTE 6
20.	V.M.H.15	289.0 254.35	1200	1160	600	66.465	
21.	V.M.H.16	311.0 254.35	1200	1640	600	66.465	
22.	V.M.H.17	339.0 254.35	1200	2255	600	66.465	
23.	V.M.H.18	297.845 453.400	1200	1585	600	65.75	
24.	V.M.H.19	297.845 439.850	1200	1995	600	65.83	
25.	V.M.H.20	316.595 439.850	1200	2592	600	65.962	
26.	V.M.H.21	335.400 439.850	1200	3560	600	66.465	

**SCHEDULE OF SEWERAGE PIPES**

SL. NO.	PIPE LINE MKD.	FROM	TO	INT. DIA. (MM)	START INV. LEVEL (O.L.)	END INV. LEVEL (O.L.)	REMARKS
1.	V.P.L.1	V.M.H.1	V.M.H.2	100	65.490	65.265	SEE NOTE 6
2.	V.P.L.2	V.M.H.2	V.M.H.3	100	65.240	64.840	SEE NOTE 6
3.	V.P.L.3	V.M.H.3	V.M.H.3A	100	64.815	64.700	SEE NOTE 6
4.	V.P.L.3A	V.M.H.3A	V.M.H.4	100	64.675	64.465	SEE NOTE 6
5.	V.P.L.4	V.M.H.4	V.M.H.5	150	64.440	64.175	
6.	V.P.L.4A	V.M.H.5	V.M.H.6	150	64.150	64.000	
7.	V.P.L.6	V.M.H.6	V.M.H.7	225	63.975	63.730	
8.	V.P.L.7	V.M.H.7	V.M.H.8	225	63.705	63.445	
9.	V.P.L.8	V.M.H.8	V.M.H.9	225	63.420	63.215	
10.	V.P.L.9	V.M.H.9	V.M.H.10	225	63.190	62.990	
11.	V.P.L.10	V.M.H.10	V.M.H.11	225	62.965	62.725	
12.	V.P.L.11	V.M.H.11	V.M.H.12	225	62.700	62.515	
13.	V.P.L.12	V.M.H.12	V.M.H.13	225	62.490	62.300	
14.	V.P.L.13	V.M.H.13	STP	225	62.275	62.195	
15.	V.P.L.5A	V.M.H.5A	V.M.H.17	100	64.710	64.335	
16.	V.P.L.5B	NOT USED					
17.	V.P.L.10A	V.M.H.10A	V.M.H.11	100	64.200	63.800	SEE NOTE 6
18.	V.P.L.11A	V.M.H.11A	V.M.H.11	100	65.30	64.757	SEE NOTE 6
19.	V.P.L.14	V.M.H.14	V.M.H.15	100	65.570	65.430	
20.	V.P.L.15	V.M.H.15	V.M.H.16	100	65.405	64.950	
21.	V.P.L.16	V.M.H.16	V.M.H.17	100	64.925	64.335	
22.	V.P.L.17	V.M.H.17	V.M.H.18	150	64.310	64.000	
23.	V.P.L.18	V.M.H.18	V.M.H.19	100	64.265	63.960	
24.	V.P.L.19	V.M.H.19	V.M.H.20	100	63.935	63.495	
25.	V.P.L.20	V.M.H.20	V.M.H.21	100	63.470	63.030	
26.	V.P.L.21	V.M.H.21	V.M.H.13	100	63.005	62.300	

**LAYOUT OF WASTE WATER DRAIN**

**NOTE:-**  
FOR TRENCH EXCAVATION IN SOLID ROCK, 100MM EXTRA DEPTH OF BEDDING REQUIRED TO ALL PIPES.  
WHERE SERVICES ARE LOCATED IN NEW ROAD CONSTRUCTION THE CLAUSES 804 & 613 OF 'SPECIFICATION FOR ROAD WORK' OF THE NATIONAL ROADS AUTHORITY (NRA) SHALL BE EXTENDED DOWN TO THE TOP SIDE OF THE SERVICE SURROUND.

- REFERENCE DRAWINGS:**
1. PLOT PLAN DRAWING NO. P0001.
  2. SLOPE, STABILIZATION, EROSION AND SEDIMENTATION CONTROL PLAN, SECTIONS & DETAILS DWG. NO. C 1003, SHEET 1 OF 2 & SHEET 2 OF 2.
  3. SITE GRADING PLAN & SECTION DWG. NO. C 1002, SHEET 1 OF 2 & SHEET 2 OF 2.
  4. PLANT FENCING DWG. NO. C 1006.
  5. PLANT ROAD DWG. NO. C 1005.
  6. STORM WATER DRAINAGE DWG. NO. C 1008.
  7. LAYOUT & DETAILS OF DUCT BANK DWG. NO. C 1004.

- NOTES**
1. ALL GRIDS AND LEVELS ARE IN METERS UNLESS NOTED OTHERWISE.
  2. ALL GRIDS ARE BASED ON PLANT GRID COORDINATES.
  3. ALL LEVELS SHOWN AS R.L. ARE RELATIVE TO D.S. DATUM.
  4. MANHOLES MAY BE CAST-IN-SITU OR PRECAST CONFORMING TO BS 5981.
  5. FOR DETAILS OF MANHOLES REFER DWG. NO. C1009 (SHT.1) & C1009 (SHT.2) BEEN 255, OF 16.
  6. LOCATIONS OF MANHOLES & PIPE LINES CLOSE TO BUILDING ARE TENTATIVE. ACTUAL LOCATION SHALL BE DECIDED AFTER FINALISATION OF NEAR BY BUILDING STRUCTURE / EQUIP.
  7. GRADE OF CONCRETE SHALL BE C-25 AS PER BS 8100.
  8. FOR GENERAL NOTES ON CONCRETE & REINFORCEMENT REFER DWG. NO. C2001 (SHT. 1 OF 2).
  9. THE SEWERAGE PIPE SHALL BE VITRIFIED CLAY PIPES CONFORMING TO BS 65.
  10. A MINIMUM OF 150 MM THICK AROUND PIPE SHALL BE ENCASED WITH CONCRETE OF GRADE C-20 WHENEVER DEPTH IS LESS THAN 1200 MM IN ROADS, 900 MM IN OTHER AREAS FOR VITRIFIED CLAY PIPES.
- LEGEND**
1. V. M. H. - SANITARY SEWERS MANHOLE MKD.
  2. SANITARY DRAIN PIPES (V.P.L. ETC.) MKD.

**AS BUILT**

**OWNER**  
TYNAGH ENERGY LIMITED  
PROJECT  
400MW COMBINED CYCLE POWER STATION  
TYNAGH CO. DUBLIN, IRELAND

**EPIC CONTRACTOR**  
GE ENERGY  
SPECIALIZED CONTRACTOR  
SPECIALIZED CONTRACTOR

**ARCHITECT**  
THE KULJIAN CORPORATION  
100, RIVERVIEW AVE.  
DUBLIN, IRELAND

REV.	DESCRIPTION	DATE	APP'D
5	REVISED AS PER GAMMA'S AS-BUILT INCORPORATION	14-08-08	PD
4	REVISED AS M.D.	13-12-04	PD
3	REVISED AS M.D.	06-12-04	PD
2	REVISED AS M.D.	16-10-04	PD
1	PIPE LINE ADDED FROM LABORATORY & REVISED AS M.D.	28-08-04	PD
0	FIRST ISSUE	28-07-04	PD

**APPROVED FOR CONSTRUCTION**

SIGNATURE: \_\_\_\_\_ DATE: \_\_\_\_\_  
 CHECKED: KR/ADG 08-05-04  
 PASSED: \_\_\_\_\_  
 APP'D: BB/DC 28-07-04

**TITLE**  
SANITARY SEWERS & DRAINAGE LAYOUT AND DETAILS

SCALE: 1:500  
 JOB NO.: K-3953  
 DRAWING NO.: C1011 SHT. 1 5

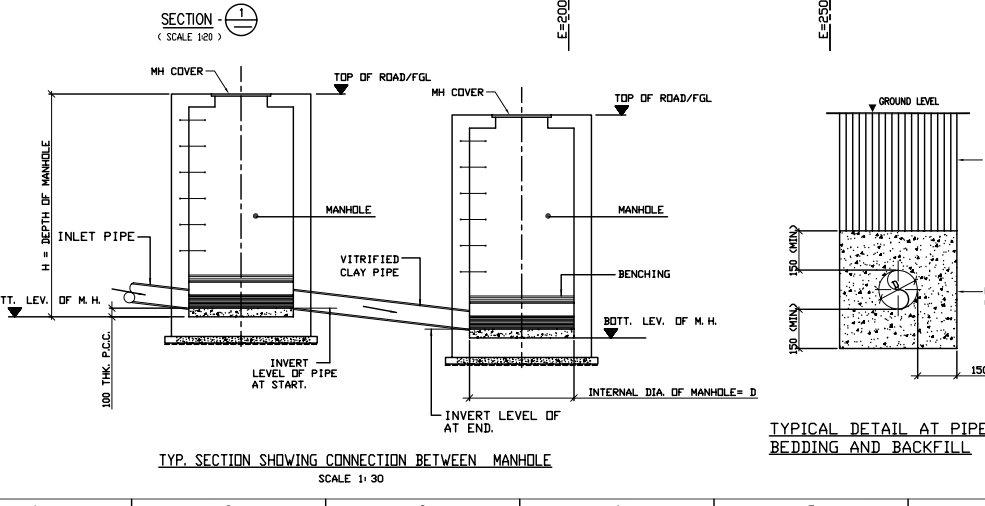

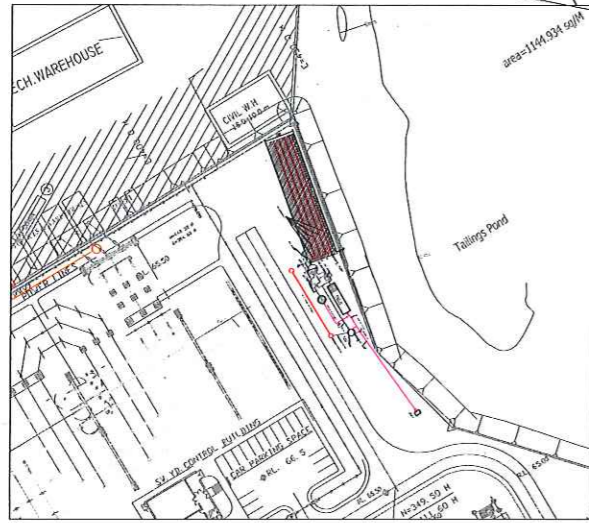
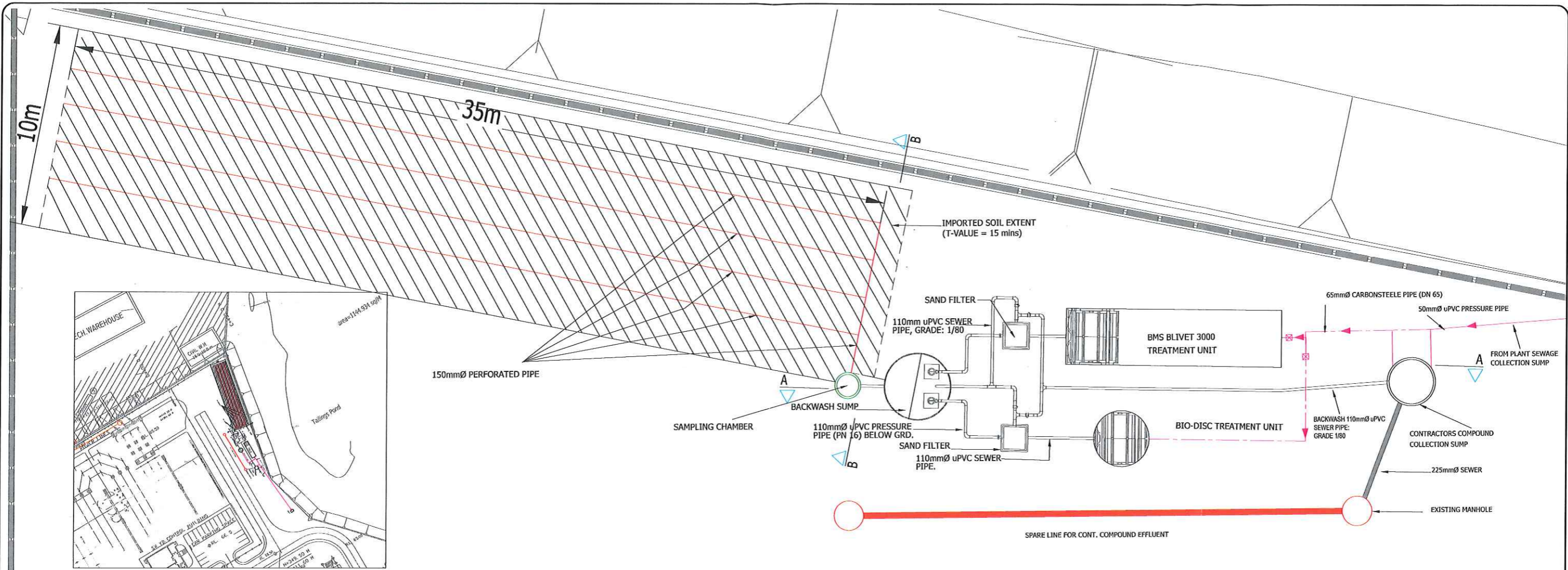

SITE LAYOUT PLAN  
SCALE: 1/1000

LAYOUT PLAN  
SCALE: 1/50

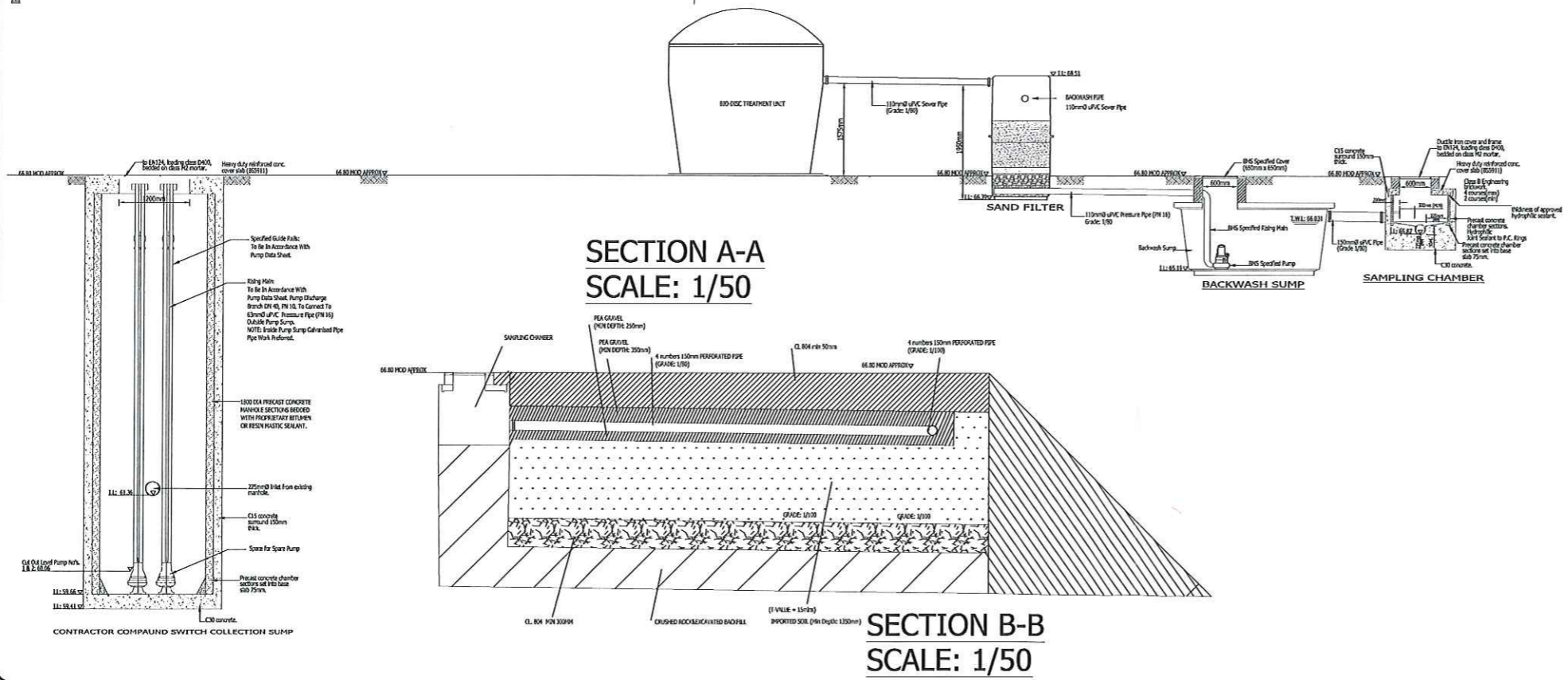

OWNER <b>TYNAGH ENERGY LIMITED</b> DUNBOYNE, IRELAND	
PROJECT <b>400MW COMBINED CYCLE POWER STATION</b> TYNAGH, CO. GALWAY, IRELAND	
EPC CONTRACTOR <b>GE ENERGY</b> GENERAL ELECTRIC COMPANY Schenectady, NY - USA	<b>GAMA</b> Power Systems Inc. Güc Sistemleri A.Ş. ANKARA, TURKEY
ARCHITECT ENGINEER <b>THE KULJIAN CORPORATION</b> ENGINEERS • ARCHITECTS • CONSULTANTS PHILADELPHIA, PA., U.S.A.	
TITLE <b>SEWAGE TREATMENT PLANT LAYOUT PLAN</b> REV	
JOB NO.	DRAWING NO. <b>AS-BUILT</b>

# Appendix E

## E.1 Proposed Drainage Layout



# Appendix F

## F.1 Greenfield Run-off Rate Calculation Report

## F.2 Surface Water Storage Calculation Report

Print

Close Report



# Greenfield runoff rate estimation for sites

www.ukstds.com | Greenfield runoff tool

Calculated by:

Site name:

Site location:

This is an estimation of the greenfield runoff rates that are used to meet normal best practice criteria in line with Environment Agency guidance "Rainfall runoff management for developments", SC030219 (2013), the SuDS Manual C753 (Ciria, 2015) and the non-statutory standards for SuDS (Defra, 2015). This information on greenfield runoff rates may be the basis for setting consents for the drainage of surface water runoff from sites.

## Site Details

Latitude:

Longitude:

Reference:

Date:

Runoff estimation approach

## Site characteristics

Total site area (ha):

## Methodology

Q<sub>BAR</sub> estimation method:

SPR estimation method:

## Soil characteristics

	Default	Edited
SOIL type:	<input type="text" value="1"/>	<input type="text" value="1"/>

HOST class:	<input type="text" value="N/A"/>	<input type="text" value="N/A"/>
-------------	----------------------------------	----------------------------------

SPR/SPRHOST:	<input type="text" value="0.1"/>	<input type="text" value="0.1"/>
--------------	----------------------------------	----------------------------------

## Hydrological characteristics

	Default	Edited
SAAR (mm):	<input type="text" value="1018"/>	<input type="text" value="1018"/>

Hydrological region:	<input type="text" value="13"/>	<input type="text" value="13"/>
----------------------	---------------------------------	---------------------------------

Growth curve factor 1 year:	<input type="text" value="0.85"/>	<input type="text" value="0.85"/>
-----------------------------	-----------------------------------	-----------------------------------

Growth curve factor 30 years:	<input type="text" value="1.65"/>	<input type="text" value="1.65"/>
-------------------------------	-----------------------------------	-----------------------------------

Growth curve factor 100 years:	<input type="text" value="1.95"/>	<input type="text" value="1.95"/>
--------------------------------	-----------------------------------	-----------------------------------

Growth curve factor 200 years:	<input type="text" value="2.15"/>	<input type="text" value="2.15"/>
--------------------------------	-----------------------------------	-----------------------------------

## Notes

### (1) Is Q<sub>BAR</sub> < 2.0 l/s/ha?

When Q<sub>BAR</sub> is < 2.0 l/s/ha then limiting discharge rates are set at 2.0 l/s/ha.

### (2) Are flow rates < 5.0 l/s?

Where flow rates are less than 5.0 l/s consent for discharge is usually set at 5.0 l/s if blockage from vegetation and other materials is possible. Lower consent flow rates may be set where the blockage risk is addressed by using appropriate drainage elements.

### (3) Is SPR/SPRHOST ≤ 0.3?

Where groundwater levels are low enough the use of soakaways to avoid discharge offsite would normally be preferred for disposal of surface water runoff.



Greenfield runoff rates	Default	Edited
Q <sub>BAR</sub> (l/s):	1.44	1.44
1 in 1 year (l/s):	1.23	1.23
1 in 30 years (l/s):	2.38	2.38
1 in 100 year (l/s):	2.81	2.81
1 in 200 years (l/s):	3.1	3.1

This report was produced using the greenfield runoff tool developed by HR Wallingford and available at [www.uksuds.com](http://www.uksuds.com). The use of this tool is subject to the UK SuDS terms and conditions and licence agreement, which can both be found at [www.uksuds.com/terms-and-conditions.htm](http://www.uksuds.com/terms-and-conditions.htm). The outputs from this tool are estimates of greenfield runoff rates. The use of these results is the responsibility of the users of this tool. No liability will be accepted by HR Wallingford, the Environment Agency, CEH, Hydrosolutions or any other organisation for the use of this data in the design or operational characteristics of any drainage scheme.

**Calculated by:**

**Site name:**

**Site location:**

This is an estimation of the storage volume requirements that are needed to meet normal best practice criteria in line with Environment Agency guidance "Rainfall runoff management for developments", SC030219 (2013), the SuDS Manual C753 (Ciria, 2015) and the non-statutory standards for SuDS (Defra, 2015). It is not to be used for detailed design of drainage systems. It is recommended that hydraulic modelling software is used to calculate volume requirements and design details before finalising the design of the drainage scheme.

# Surface water storage requirements for sites

[www.uksuds.com](http://www.uksuds.com) | Storage estimation tool

## Site Details

**Latitude:**

**Longitude:**

**Reference:**

**Date:**

**Site characteristics**

Total site area (ha):	1.53
Significant public open space (ha):	0
Area positively drained (ha):	1.53
Impermeable area (ha):	1.53
Percentage of drained area that is impermeable (%):	100
Impervious area drained via infiltration (ha):	0
Return period for infiltration system design (year):	10
Impervious area drained to rainwater harvesting (ha):	0
Return period for rainwater harvesting system (year):	10
Compliance factor for rainwater harvesting system (%):	66
Net site area for storage volume design (ha):	1.53
Net impermeable area for storage volume design (ha):	1.53
Pervious area contribution to runoff (%):	30

\* where rainwater harvesting or infiltration has been used for managing surface water runoff such that the effective impermeable area is less than 50% of the 'area positively drained', the 'net site area' and the estimates of  $Q_{BAR}$  and other flow rates will have been reduced accordingly.

**Design criteria**

Climate change allowance factor:	1.4
Urban creep allowance factor:	1.1
Volume control approach	Use long term storage
Interception rainfall depth (mm):	5
Minimum flow rate (l/s):	5

**Methodology**

esti	IH124	
$Q_{BAR}$ estimation method:	Calculate from SPR and SAAR	
SPR estimation method:	Calculate from SOIL type	
Soil characteristics	Default	Edited
SOIL type:	1	1
SPR:	0.1	0.1
Hydrological characteristics	Default	Edited
Rainfall 100 yrs 6 hrs:	--	61
Rainfall 100 yrs 12 hrs:	--	73
FEH / FSR conversion factor:	1	1
SAAR (mm):	1018	1018
M5-60 Rainfall Depth (mm):	17	17
'r' Ratio M5-60/M5-2 day:	0.3	0.3
Hydrological region:	13	13
Growth curve factor 1 year:	0.85	0.85
Growth curve factor 10 year:	1.4	1.4
Growth curve factor 30 year:	1.65	1.65
Growth curve factor 100 years:	1.95	1.95
$Q_{BAR}$ for total site area (l/s):	0.4	0.4
$Q_{BAR}$ for net site area (l/s):	0.4	0.4

Site discharge rates	Default	Edited
1 in 1 year (l/s):	5	5
1 in 30 years (l/s):	5	5
1 in 100 year (l/s):	5	5

Estimated storage volumes	Default	Edited
Attenuation storage 1/100 years (m <sup>3</sup> ):	1468	1468
Long term storage 1/100 years (m <sup>3</sup> ):	0	0
Total storage 1/100 years (m <sup>3</sup> ):	1468	1468

This report was produced using the storage estimation tool developed by HRWallingford and available at [www.uksuds.com](http://www.uksuds.com). The use of this tool is subject to the UK SuDS terms and conditions and licence agreement, which can both be found at <http://uksuds.com/terms-and-conditions.htm>. The outputs from this tool have been used to estimate storage volume requirements. The use of these results is the responsibility of the users of this tool. No liability will be accepted by HR Wallingford, the Environment Agency, CEH, Hydrosolutions or any other organisation for the use of these data in the design or operational characteristics of any drainage scheme.

# Appendix G

## G.1 Percolation Test



**SOIL CHARACTERISATION AND  
SITE SUITABILITY ASSESSMENT REPORT  
TE REF: 22/089 TE**

**TYNAGH ENERGY LIMITED  
TYNAGH POWER PLANT  
DERRYFRENCH  
LOUGHREA  
CO. GALWAY  
IRELAND**

**IN ACCORDANCE WITH  
EPA CODE OF PRACTICE  
WASTEWATER TREATMENT AND DISPOSAL  
SYSTEMS SERVING SINGLE HOUSES 2021 &  
TREATMENT SYSTEMS FOR  
SMALL COMMUNITIES, BUSINESS, LEISURE  
CENTRES AND HOTELS**



**Traynor Environmental Ltd  
Belturbet Business Park, Creeny, Belturbet  
Co. Cavan  
Tel: +353 49 9522236  
Fax: +353 49 9522808  
Web: [www.traynorenvironmental.com](http://www.traynorenvironmental.com)**

# **SITE CHARACTERISATION FORM FOR AN ON-SITE WASTEWATER TREATMENT SYSTEM**

## **CONTENTS**

<b>1.0</b>	<b>GENERAL DETAILS</b>
<b>2.0</b>	<b>GENERAL DETAILS</b>
<b>3.0</b>	<b>ON SITE ASSESSMENT</b>
3.1	<i>VISUAL ASSESSMENT</i>
3.2a	Subsurface Percolation Test for Subsoil
	<i>Step 1 Test Hole Preparation</i>
	<i>Step 2 Pre-Soaking Test Holes</i>
	<i>Step 3 Measuring <math>T_{100}</math></i>
	<i>Step 4 Standard Method (where <math>T_{100} \leq 210\text{min}</math>)</i>
3.2b	Surface Percolation for Soil
	<i>Step 1 Test Hole Preparation</i>
	<i>Step 2 Pre-Soaking Test Holes</i>
	<i>Step 3 Measuring <math>T_{100}</math></i>
	<i>Step 4 Standard Method (where <math>T_{100} \leq 210\text{min}</math>)</i>
<b>4.0</b>	<b>CONCLUSIONS OF SITE CHARACTERISATION</b>
<b>5.0</b>	<b>SITE ASSESSORS DETAILS</b>
<b>6.0</b>	<b>PHOTOGRAPHS OF THE SITE</b>
<b>7.0</b>	<b>EPA/FAS CERTIFICATE</b>
<b>8.0</b>	<b>INSURANCE DETAILS.</b>

**1.0 GENERAL DETAILS (From planning application)**

<b>Name(S)</b>	Tynagh Energy Limited	
<b>Address of Correspondance</b>	Tynagh Power Plant Derrtfrench Loughrea Co. Galway	
<b>Site Location and Townland</b>	Tynagh Power Plant Derrtfrench Loughrea Co. Galway	

**Proposed Water Supply:**

Mains:  Private Well/Borehole  Group Well/Borehole

**2.0 GENERAL DETAILS (From planning application)**

<b>Soil Type, (Specify Type):</b>	Soil Association 32 Degraded Grey Brown Podzolics (50%), Peat(15%), Brown Earths (15%), Gleys (10%) Podzols (10%)		
<b>Subsoil, (Specify Type):</b>	Silt/Clay		
<b>Bedrock Type:</b>	Sandstones Westphalian Shales		
<b>Aquifer Category:</b>	Regionally Important <input type="checkbox"/>	Locally Important <input checked="" type="checkbox"/>	Poor <input type="checkbox"/>
<b>Vulnerability:</b>	Extreme <input type="checkbox"/>	High <input checked="" type="checkbox"/>	Moderate <input type="checkbox"/> Low <input type="checkbox"/>
<b>Groundwater Body:</b>	IE_SH_G_237	<b>Status</b>	At Risk
<b>Name of Public/Group Scheme Water Supply within 1km:</b>	Unknown		
<b>Source Protection Area:</b>	ZOC <input type="checkbox"/> n/a	SI <input type="checkbox"/> n/a	SO <input type="checkbox"/> n/a
<b>Groundwater Protection Response:</b>	R1		
<b>Presence of Significant sites (Archaeological, natural and historical):</b>	None evident within the locality		
<b>Past experience in the area:</b>	Variable percolation characteristics of the topsoil and subsoil materials.		

*R1 = Acceptable subject to normal good practice. Site may be suitable for discharge to ground, if the minimum depths are met on the site and if there exists suitable percolation. As the soil type in the area is Degraded Grey Brown Podzolics (50% of the land area), and as the area is mapped as 'High' Vulnerability. Groundwater as a resource will be at risk if the minimum depths required are not achieved on the site, or if the percolation rate is too rapid. Older wells in the area may also be at risk, if the minimum separation distances are not adhered to. Groundwater and wells are therefore the main targets, following the desk study. Given the response and the aquifer type, the site is potentially suitable for a conventional septic tank system if the minimum depths required are met on the site, if the minimum separation distances can be met, and if the percolation rate is adequate.*



### 3.0 ON-SITE ASSESSMENT

#### 3.1 Visual Assessment

<b>Landscape Position</b>	<i>Relatively Flat</i>			
<b>Slope</b>	<i>Steep &lt;1:5</i>	<i>Shallow 1.5 to 1.20</i>	<i>Relatively Flat</i>	✓
<b>Slope Comment</b>				<i>Sloping in southeast direction</i>

*Surface features within a minimum of 250 metres (Distances to features should be noted in metres)*

<b>Houses</b>	<i>Power Plant located &gt;10m southwest from the percolation area (pa).</i>
<b>Existing Land Uses</b>	<i>Gravel Area</i>
<b>Vegetation Indicators</b>	<i>None</i>
<b>Groundwater Flow Directions</b>	<i>Southeast direction</i>
<b>Ground Condition</b>	<i>Ground conditions are best described as dry and firm in the pa.</i>
<b>Site Boundaries</b>	<i>Fence located to the north, east and west from the pa. Field is located to the north south &amp; west of the pa.</i>
<b>Roads</b>	<i>Located road located &gt;10m west from the pa.</i>
<b>Outcrops (Bedrock and/or subsoil)</b>	<i>None Identified or Evident within the locality.</i>
<b>Surface water ponding</b>	<i>No surface water ponding was evident in the pa when examined on 09.02.22. It must be noted that weather conditions prior to the site assessment taking place was generally dry conditions.</i>
<b>Lakes</b>	<i>None occur within 50m of the pa.</i>
<b>Beaches/Shellfish Areas</b>	<i>None occur within 200m of the pa.</i>
<b>Wetlands</b>	<i>None occur within 200m of the pa.</i>
<b>Karst Features</b>	<i>None occur within 200m of the pa.</i>
<b>Watercourses/Streams</b>	<i>None occur within 10m of the pa.</i>
<b>Drainage Ditches</b>	<i>None occur within 10m of the pa</i>
<b>Springs</b>	<i>None occur within 50m from the pa.</i>

## Wells

*If a well is to be bored onsite it should be located at least 30m up-gradient from the ppa; this will therefore be outside the minimum separation distances of the Groundwater Protection Responses of GSI/EPA/DoELG and the EPA Code of Practice (2021).*

*As all the wells in the locality will therefore meet the required separation distances of the Groundwater Protection Responses of GSI/EPA/DoELG and the EPA Code of Practice (2021), none are deemed to be at risk from the proposed polishing filter's installation.*

***Integrate the information above in order to comment on:***

***1. The potential suitability of the site:***

***The site still seems suitable for discharge to ground.***

***2. Potential targets at risk:***

***Following the desk study surface water was thought not to be at risk; this was corroborated during the visual assessment.***

***There appears to be few issues with respect to impermeability. From this, surface water does not seem to be a potential target,***

***Groundwater is still a target following the visual assessment, unless the minimum depths required are met on the site and there exists adequate percolation.***

***3. The suitability of the site to treat the wastewater:***

***Following the visual assessment it is seen that all appropriate separation distances can be met and the site seems well drained, and pending confirmation of the presence of adequate depths of unsaturated soil and subsoil within the percolation area, as well as sufficient percolation rates under the site, the site should be suitable for treating wastewater adequately.***



### 3.2a Subsurface Percolation Test for Subsoil

#### Step 1 Test Hole Preparation

<b>Percolation Test Hole</b>	<b>1</b>	<b>2</b>	<b>3</b>
Depth from ground surface to top of hole (mm) (A):	600	600	600
Depth from ground surface to base of hole (mm) (B):	1000	1000	1000
Depth of hole (mm) (B-A):	400	400	400
Dimensions of hole [length x breadth (mm)]:	300 x 300	300 x 300	300 x 300

#### Step 2 Pre-Soaking Test Holes

<b>Pre-soak</b>	<b>Date</b>	09.02.22	09.02.22	09.02.22
<b>start</b>	<b>Time</b>	10.00	10.00	10.00
<b>2<sup>nd</sup> pre-soak</b>	<b>Date</b>	09.02.22	09.02.22	09.02.22
<b>start</b>	<b>Time</b>	11.00	11.00	11.00

Each hole should be pre-soaked twice before the test is carried out. Each hole should be empty before refilling.

#### Step 3 Measuring T<sub>100</sub>

<b>Percolation Test Hole</b>	<b>1</b>	<b>2</b>	<b>3</b>
Date of Test	09.02.22	09.02.22	09.02.22
Time Filled to 400mm	12.15	12.15	12.15
Time Water Level at 300mm	12.46	12.48	12.50
Time to drop 100mm (T <sub>100</sub> )	31.00	33.00	35.00
Average T <sub>100</sub>			33.00

If T<sub>100</sub> > 480mins then Subsurface Percolation value > 120 – site unsuitable for discharge to ground  
 If T<sub>100</sub> ≤ 210mins then go to Step 4  
 If T<sub>100</sub> ≥ 210mins then go to Step 5

**Step 4 Standard Method (where  $T_{100} \leq 210$ min)**

Percolation Test Hole	1			2			3		
	Start Time at 300mm	Finish Time at 200mm	$\Delta t$ (min)	Start Time at 300mm	Finish Time at 200mm	$\Delta t$ (min)	Start Time at 300mm	Finish Time at 200mm	$\Delta t$ (min)
1	12.47	13.20	33.00	12.49	13.25	36.00	12.51	13.30	39.00
2	13.21	13.59	38.00	13.26	14.08	42.00	13.31	14.16	45.00
3	14.00	14.45	45.00	14.09	14.59	50.00	14.17	15.11	54.00
Average $\Delta t$			38.60			42.60			46.00
	Average $\Delta t/4 =$ [Hole No. 1]		9.60	Average $\Delta t/4 =$ [Hole No. 2]		10.60	Average $\Delta t/4 =$ [Hole No. 2]		11.50
Result of Test: Subsurface Percolation Value:			10.56	min/25mm					

Comments
<p><b>Result of Surface Percolation: 10.56 min/25mm.</b></p> <p><b>Good Percolation Characteristics of the Surface Material.</b></p>

### 3.2b Surface Percolation for Soil

#### Step 1 Test Hole Preparation

<b>Percolation Test Hole</b>	<b>1</b>	<b>2</b>	<b>3</b>
Depth from ground surface to top of hole (mm) (A):	0	0	0
Depth from ground surface to base of hole (mm) (B):	400	400	400
Depth of hole (mm) (B-A):	400	400	400
Dimensions of hole [length x breadth (mm)]:	300 x 300	300 x 300	300 x 300

#### Step 2 Pre-Soaking Test Holes

<b>Pre-soak start</b>	<b>Date</b>	09.02.22	09.02.22	09.02.22
	<b>Time</b>	10.00	10.00	10.00
<b>2<sup>nd</sup> pre-soak start</b>	<b>Date</b>	09.02.22	09.02.22	09.02.22
	<b>Time</b>	11.00	11.00	11.00

Each hole should be pre-soaked twice before the test is carried out. Each hole should be empty before refilling.

#### Step 3 Measuring T<sub>100</sub>

<b>Percolation Test Hole</b>	<b>1</b>	<b>2</b>	<b>3</b>
Date of Test	09.02.22	09.02.22	09.02.22
Time Filled to 400mm	12.20	12.20	12.20
Time Water Level at 300mm	12.35	12.39	12.41
Time to drop 100mm (P <sub>100</sub> )	15.00	19.00	21.00
Average T <sub>100</sub>			18.30

If T<sub>100</sub> > 480 minutes then Surface Percolation value > 90 – site unsuitable for discharge to ground  
 If T<sub>100</sub> ≤ 210mins then go to Step 4  
 If T<sub>100</sub> ≥ 210mins then go to Step 5

Step 4 Standard Method (where  $T_{100} \leq 210\text{min}$ )

Percolation Test Hole	1			2			3		
	Start Time at 300mm	Finish Time at 200mm	$\Delta t$ (min)	Start Time at 300mm	Finish Time at 200mm	$\Delta t$ (min)	Start Time at 300mm	Finish Time at 200mm	$\Delta t$ (min)
1	12.36	12.52	16.00	12.40	13.01	21.00	12.42	13.05	23.00
2	12.53	13.11	18.00	13.02	13.26	24.00	13.06	13.33	27.00
3	13.12	13.35	23.00	13.27	13.57	30.00	13.34	14.08	34.00
Average $\Delta t$			19.00			25.00			28.00
	Average $\Delta t/4 =$ [Hole No. 1]		4.75	Average $\Delta t/4 =$ [Hole No. 2]		6.25	Average $\Delta t/4 =$ [Hole No. 2]		7.00
Result of Test : Surface Percolation Value	6.00		min/25mm						
<b>Comments</b>									
<p><b>Result of Surface Percolation: 6.00 min/25mm.</b></p> <p><b>Good Percolation Characteristics of the Surface Material.</b></p>									

#### 4.0 CONCLUSIONS of SITE CHARACTERISATION:

Percolation test results: Surface:  Sub-surface:

Not suitable for Development

Suitable for Development

#### 5.0 SITE ASSESSOR DETAILS

Company:

Prefix:  First Name:  Surname:

Address:

Qualifications/Experience:

Date of Report:

Phone:  Fax:  E-mail:

Indemnity Insurance Number:

Signed:

  
**Nevin Traynor**

*BSc. Env, H.Dip I.T, Cert SHWW, EPA/FAS Cert.*

*For Traynor Environmental Ltd*



6.0 SITE PHOTOGRAPHS

*Facing East From the  
Trial Hole Excavation*



*Facing North From the  
Trial Hole Excavation*



*Facing South From the  
Trial Hole Excavation*



*Facing West From the  
Trial Hole Excavation*



**Percolation ("Sub-Surface") Test 1**



**Percolation ("Sub-Surface") Test 2**



**Percolation ("Sub-Surface") Test 3**



**Percolation ("Surface") Test 1**



**Percolation ("Surface") Test 2**



**Percolation ("Surface") Test 3**



Maps Used As Part of the EPA Site Suitability Assessment

**Groundwater/Aquifer Map**



*From the GSI  
Groundwater Aquifer  
Map Site is classified as  
Locally Important Aquifer  
- Bedrock which is  
Moderately Productive  
only in Local Zones*

**Vulnerability Map**

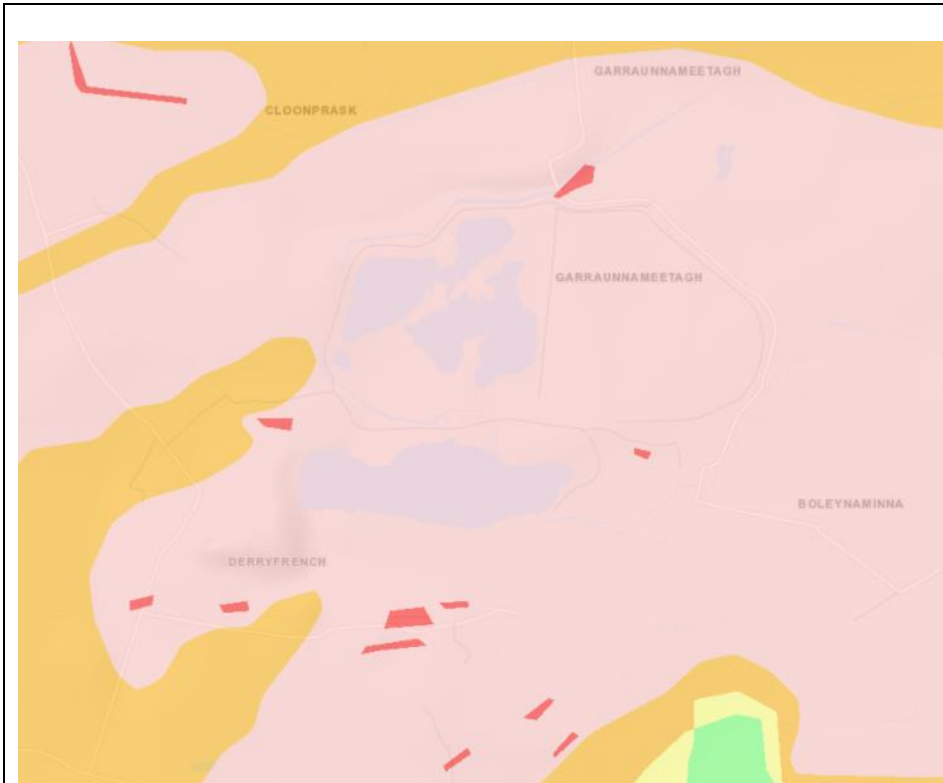

*From the GSI Vulnerability  
Map Site is classified as  
High*

**Bedrock Map**



**From the GSI Bedrock Map Site is classified as Sandstones Westphalian Shales**

**Teagasc Subsoil Map**

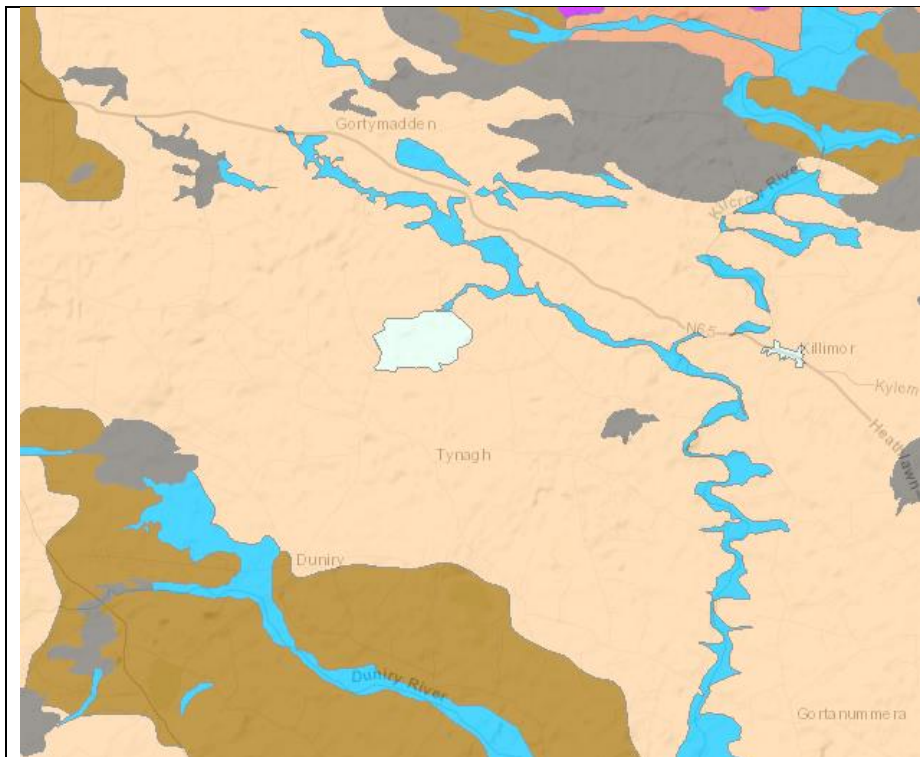

**From the Teagasc Subsoil Map Site is classified as Coarse loamy drift with limestones**



## 8.0 P.I INSURANCE

### Griffiths & Armour Europe DAC

Alexandra House  
The Sweepstakes  
Ballsbridge  
Dublin 4

+353 (0)1 664 1409  
+353 (0)1 634 9001  
Info@griffithsandarmour.com  
griffithsandarmour.com



## PROFESSIONAL INDEMNITY INSURANCE

We confirm the following details relating to our client's Professional Indemnity Insurance:

**Insured:** Traynor Environmental Ltd

**Address:** Belturbet Business Park  
Greeny  
Belturbet  
Co. Cavan  
H14AY94

**Lead Insurer(s):** Axis Specialty Europe SE

**Period of Insurance:** 12 July 2021 to 11 July 2022

**Policy Number:** 20/1/04786

**Limit of Indemnity:** €1,500,000 any one claim and unlimited in the period of insurance

Signed:

Graeme Tinney  
Chief Executive Officer  
Griffiths & Armour Europe DAC

Date: 22 June 2021

The policy is subject to the insuring agreements, exceptions, exclusions, limitations, conditions and declarations contained therein. The above is accurate at the date of signature. No obligation is imposed herein on the signatory to advise of any alteration.

Directors: G Tinney C Evans (UK) D J Whalley (UK) T Cosgrove (Non-Executive)  
Registered in Ireland No. 632268  
Registered Office: G House 108 Furze Road Sandycroft Dublin 18 Ireland  
Griffiths & Armour Europe Designated Activity Company is regulated by the Central Bank of Ireland

Disclosure

